

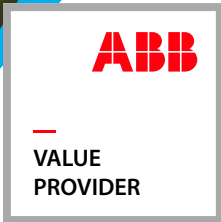

## PowerClad 5kV Metal-Clad Medium Voltage Switchgear

Spike Electric offers a range of medium voltage solutions within the 5kV category, designed to accommodate both indoor and outdoor settings, including non-walk-in and fully enclosed outdoor types. Our 5kV switchgear, mechanically ready and rated for 25kA thru 63kA, comes with the option for CSA certification when necessary. Additionally, it undergoes rigorous testing in accordance with ASCE7-10 standards to ensure it surpasses the expectations set by IBC & CBC regulations.



Valued Partner Acknowledgment Statement: Spike Electric Controls has partnered with ABB as a Value Add Partner, blending ABB's cutting-edge technology with our expertise in electrical solutions to elevate industry standards. This partnership aims to globally enhance system efficiency, reliability, and sustainability, delivering sophisticated electrification solutions to our customers. Additionally, this alliance includes dual branding of our Switchgear products and extends ABB's warranties through Spike's comprehensive Switchgear solutions, ensuring quality and reliability.



# PowerClad

5kV Metal-Clad  
Medium Voltage Switchgear



- Superior cycloaliphatic epoxy insulation—a void-free insulating material with outstanding electrical and mechanical characteristics, such as track resistance, dielectric strength, and fungus resistance, even in harsh industrial environment—is used throughout the circuit breaker as primary phase-to-phase and phase-to-ground insulation.
- Axial-magnetic, copper-chrome contacts are used in 5kV vacuum interrupters to provide superior dielectric strength, better performance characteristics, and lower chop current.
- High power laboratory tests prove ADVAC breakers are capable of 50 to 200 full fault current interruptions
- Easy inspection and accessibility is afforded by front mounted stored energy operating mechanism. The same basic mechanism is used on all ratings, which requires a minimum investment in spare parts.
- All 5kV circuit breakers are horizontal Drawout and fixed design, which provide connect, test and disconnect position. A latch secures the breaker in the connected and disconnected/test position. The circuit breaker is designed to roll directly on the floor.
- Circuit breaker compartment is designed to interface with type ADVAC 5kV circuit breaker. It includes floor-mounted breaker pan assembly (levering assembly) with all safety interlocks required by the metal-clad design. Cell mounted guide rails accurately guide the breaker into the cell during levering, and ensure correct alignment of the circuit breaker primary disconnects with the cell primary contacts when breaker reaches connected position.
- Coding plates are provided to ensure only correct breaker rating can be installed in the cell.
- Automatic steel shutters cover cell primary contacts when circuit breaker is withdrawn from its connected position, to prevent persons from accidentally touching the stationary primary cell contacts. Each shutter can be padlocked in the closed or open position. It can also be manually latched open as required for maintenance.
- A separate control compartment is provided for installation of protection, metering and control devices. No devices are located on circuit breaker compartment door.
- Rear of the switchgear is divided in main bus and cable compartments, isolated from each other by grounded metal barriers. Sufficient space is available for customer's top or bottom entry power cables. Bus duct terminations can also be supplied. A bare copper ground bus is provided along the entire lineup, with an extension in each cable compartment for termination of power cable shields.

## General Description:

### 5kV Metal-Clad Switchgear:

Spike Electric Controls PowerClad switchgear family is designed for use in applications with distribution voltages up to 5kV maximum. Typical applications include not only new construction but also replacement for older air-break, minimum oil or SF6 switchgear. The circuit breaker and switchgear will meet industry requirements for greater safety, quality, superior reliability and minimal maintenance while providing higher insulation levels in less space than other breaker types, thus reducing overall switchgear size for significant space savings.

### Ratings:

- Maximum rated voltage: 5kV rms
- BIL withstand: 60kV peak
- Maximum symmetrical interrupting with K = 1: 16kA, 25kA, 31.5kA, 40kA, 35kA, 50kA, 63kA
- Continuous current:  
Circuit breakers - up to 4000A  
Switchgear main bus - up to 4000A

## Features:

### 5kV Vacuum Circuit Breaker:

- Corona-free design increases circuit breaker reliability and in-service life by maintaining insulation integrity.

### 5kV Switchgear Assembly:

- The 5kV switchgear assembly is a corona-free, metal-clad design. It integrates many features and advantages from the 5, 15kV PowerClad designs, with additional modifications necessary for 5kV applications.
- Industry-leading cycloaliphatic epoxy supports are used for primary phase-to-phase and phase-to-ground insulation throughout, providing 60kV BIL and 80kV (1 minute) power frequency withstand capability.
- All primary bus conductors are insulated for full 5kV by fluidized epoxy coating. All buses are fabricated from 100% conductivity copper. Bus joints are silver or tin-plated as required, and covered with Spike Electric Control's preformed insulating boots to maintain metal-clad integrity.





# PowerClad

5kV Metal-Clad  
Medium Voltage Switchgear



### Optional Accessories and Features:

- UL / cUL listing
- Copper tin-plated bus
- Insulated bus and bus boots over joints
- 80kA momentary bus rating
- Automatic transfer switch
- Weather resistant
- Dust resistant
- NEMA 2 drip-proof enclosure
- Rear doors (full height or double)
- Vertical barriers
- Rodent barriers
- Bottom closure plates
- Seismic Zone 4 bracing
- Tamper resistant hardware
- Auxiliary switches (2NO-2NC)
- Thermostat
- Space heater (standard on outdoor, optional on indoor)
- Porcelain insulators
- Customer metering
- Surge arresters
- Mimic bus
- Space heater switch
- Ground studs
- Convenience light
- Duplex receptacle
- Top hat
- Run back bus
- And more!

### Features Cont:

- Ampacity: 1200A, 2000A, 3000A, 4000A
- Basic Insulation Level (BIL): 60kV BIL max (Breaker 170kV BIL)
- Advanced ABB vacuum circuit breaker technology.
- Indoor/outdoor compatibility.
- Metal-clad Switchgear, compartmentalized structure.
- Rear connection access.
- Main-tie-main automatic transfer configurations available.
- Breaker & Drawout PT integration in feeder sections.
- 5kV voltage, 1200A, 2000A, 3000A, and 4000A.
- Breaker interrupter up to 40kAIC.

### COMPLIANCES:

#### ANSI/IEEE C37.20.2

Metal-Clad Switchgear

#### ANSI/IEEE C37.04

Rating Structure for High Voltage Circuit Breakers

#### ANSI/IEEE C37.54

Indoor HV Breakers in Metal Enclosure Conformance Test

#### ANSI/IEEE C37.55

Medium Voltage Metal-Clad Assemblies

#### ANSI/IEEE C37.09

Test Procedure for AC HV Breakers on Sym Current basis

#### ASCE7-10 Standards

Compliance for structural design.

#### IBC & CBC

Compliance with building codes.

#### Buy American Act

Certification available upon request.

CSA Certified





# PowerClad

5kV Metal-Clad  
Medium Voltage Switchgear

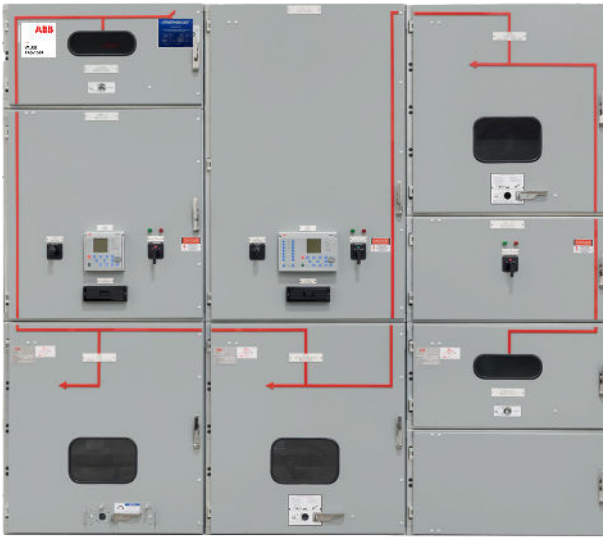

## Construction Doors:

PowerClad front doors consist of the breaker compartment, auxiliary unit compartments and LV compartments. These doors are provided with a single handle, multi-point latch (MPL) as standard. Bolted doors are available as an option. All doors are hinged on the left as standard (when facing the front door). Right-hand hinged doors are available as an option.

Rear doors on the PowerClad product are used to access the high voltage cable compartments. These doors are available in the following configurations:

- Full height hinged and bolted
- Split doors (top compartment/bottom compartment) hinged and bolted
- Full height hinged with multi-point latch (MPL) is optional
- Bolted, non-hinged full height or split doors are also available as an option.
- All front and rear doors are constructed using 12-gauge painted steel.

Padlock provisions are available on all front and rear doors. These padlock provisions are used to lock the door closed to prevent access to the compartment interiors. On breaker compartment doors, padlock provisions are also supplied on the racking release lever, to prevent unintended racking of the breaker.

Breaker and auxiliary compartment unit doors include a viewing window used for observing the position and status of the components inside the compartment with the door closed. These doors can also be provided with the SmartRack mounting provisions for remote racking applications.

Due to the small footprint design, installation of protection and control devices on the breaker and auxiliary unit doors are not possible without adding the optional 10-inch front extension to the front of the frame. With the 10-inch front extension, protection and control relaying can be installed on these doors.

## Compartment Types Circuit Breaker Compartment

### Circuit Breaker Compartments:

PowerClad circuit breaker compartments are designed for operator safety by providing one large viewing window and automatic latching, three-position, closed door racking. As an option, mechanical breaker position indicators, viewable from outside the compartment, with the door closed are available. The circuit breakers have self-aligning, fully automatic primary and secondary contacts allowing operators to keep the door closed throughout the racking operation.

### Unique Racking System & Interlocks:

The racking system is unique and features a three-position closed door system for all circuit breakers. The racking mechanism is integral to the circuit breaker, so moving parts can be inspected and maintained outside the circuit breaker compartment and away from energized primary parts.

A solid stationary ground contact engages the grounding contact of the circuit breaker prior to the coupling of the primary or secondary contacts and is continuous during the racking operation

### The three racking positions are defined as follows:

- Connected: Primary and secondary (control) contacts are engaged
- Disconnected: Primary and secondary (control) contacts are disengaged
- Test: Primary contacts are disengaged. Secondary (control) contacts are engaged for incell breaker testing.



### Racking System Includes All Necessary Interlocks:

In compliance with ANSI/IEEE standards to assure proper sequencing and safe operation. For improved safety, the interlocking system prohibits operation of the breaker while in an intermediate position and prohibits insertion of an improperly rated breaker.

### Secondary Disconnect System:

A dual (50-pin) self-aligning secondary disconnect for control circuitry is provided as a standard feature. The female portion resides in the circuit breaker module. Potentially energized contacts are recessed and are touch safe. No manual connection of secondary contacts required.

### Primary Shutters:

Primary shutters automatically cover primary contacts when the breaker is not in the connected position. The shutters may be grounded metal or optional Lexan material. Lexan is standard for 27kV applications. Primary shutter opening and closing is forced by circuit breaker movement, rather than relying on springs or gravity. A locking mechanism prevents opening of the shutter when the circuit breaker is removed.

CTs on epoxy bushings      Primary shutters

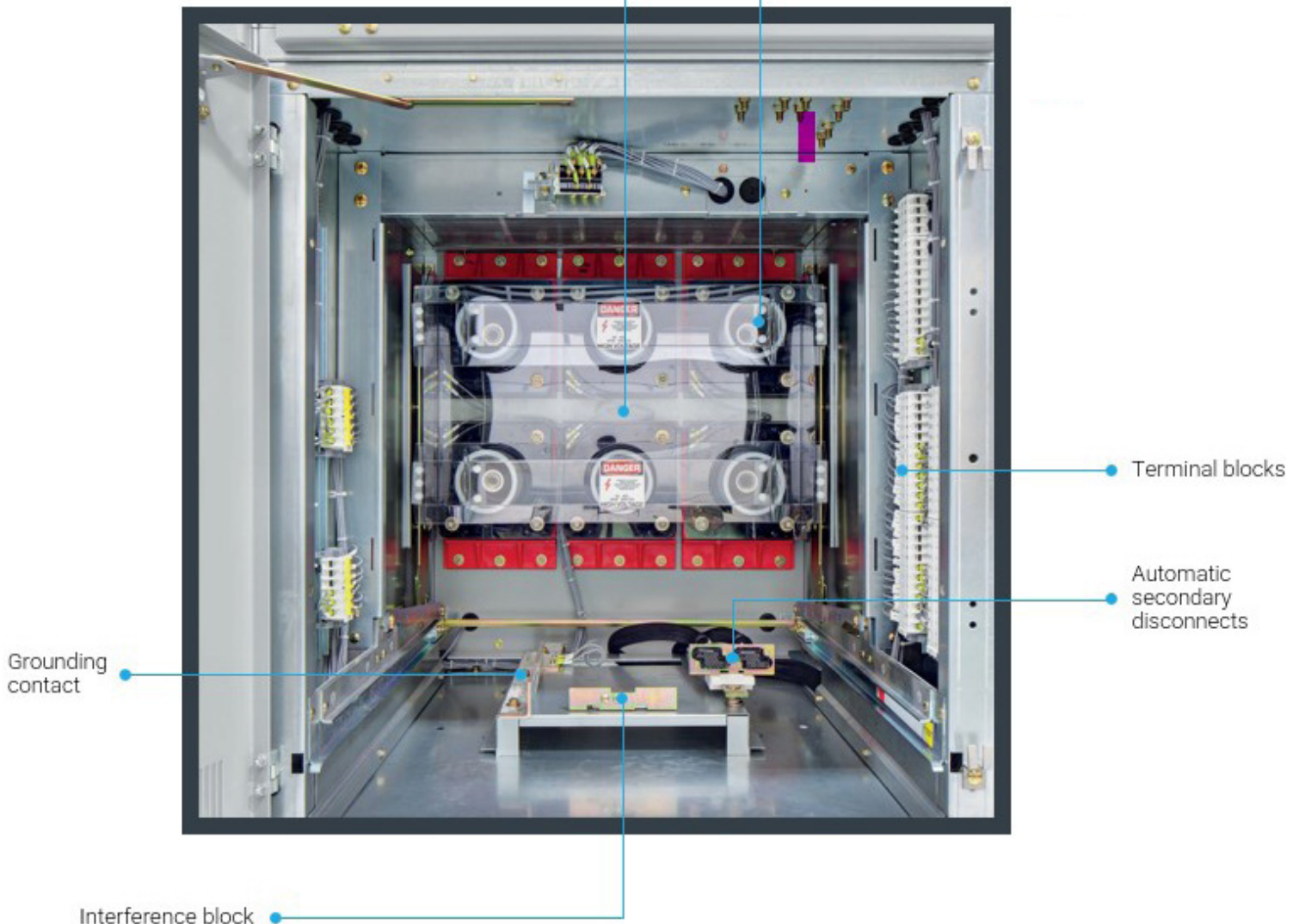



# PowerClad

5kV Metal-Clad  
Medium Voltage Switchgear



## Technical & Application Guide:

Low voltage instrument module isolated for maximum safety when working in with low voltage circuits

LVC door panel 57" -->

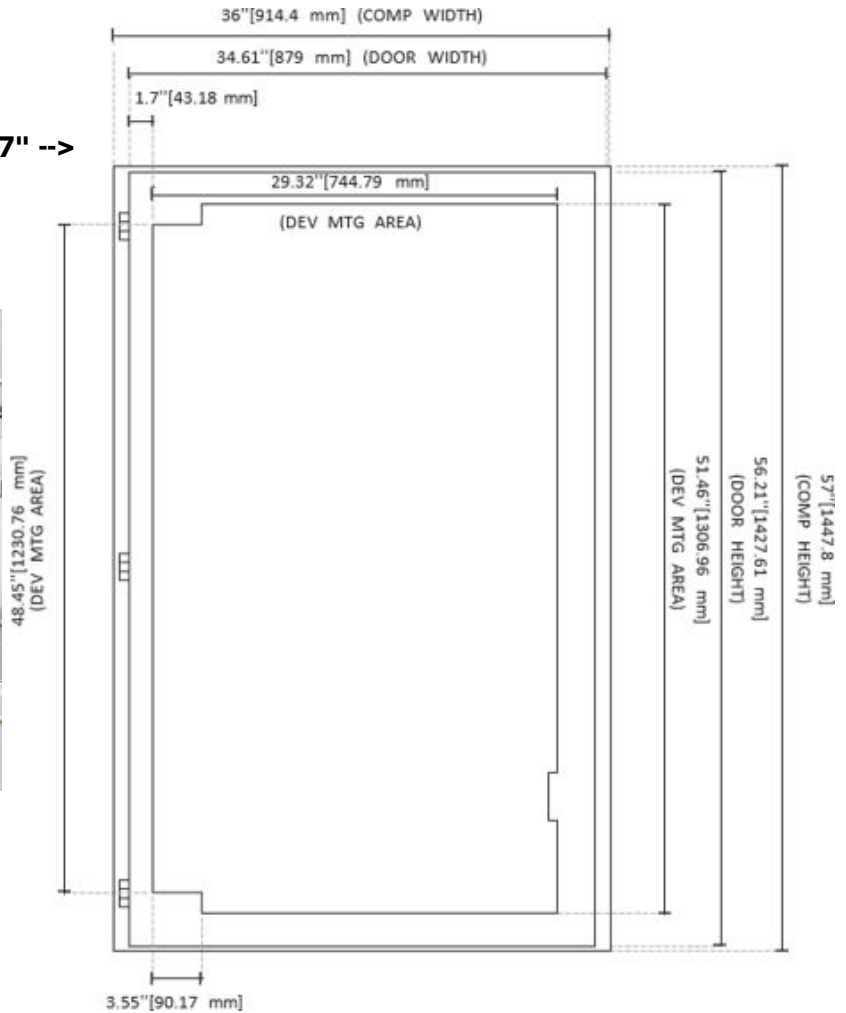
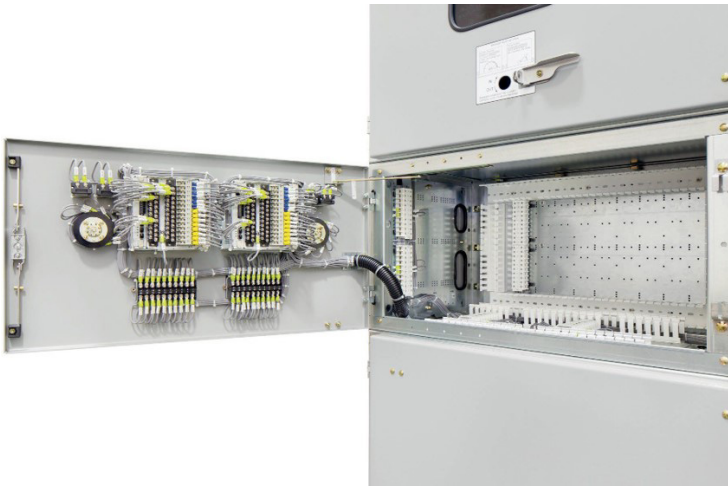

<--LVC door panel 38"

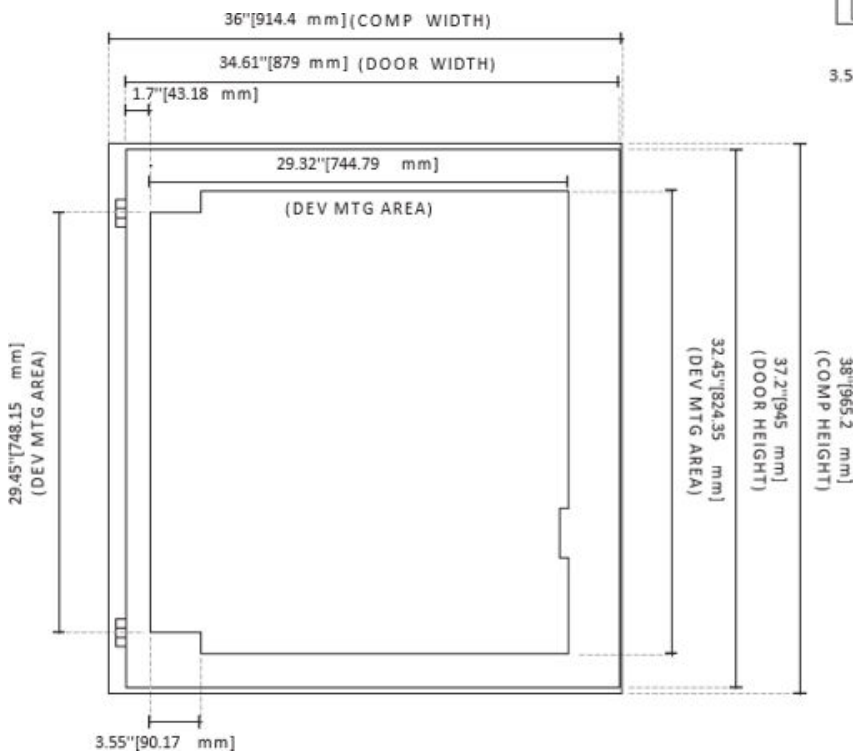



# PowerClad

5kV Metal-Clad  
Medium Voltage Switchgear



- 75% lower power consumption accessories for reduced battery bank systems.
- Global 24hour Service and support.
- Breaker + cassette solutions available for a faster engineering design.

### Maximize Your Output:

- 50% less maintenance time with modular accessory replacement.
- Smart Coil accessories provide fast, low energy response with intelligent coil monitoring.
- ABB EL spring mechanism used on over 2 million breakers installed globally, modular design that is readily accessible and easily maintained to reduce downtime.
- Voltage transformers are equipped with integral top-mounted primary fuses and installed in an auxiliary compartment. Two auxiliary compartments can be provided in one vertical section. Each auxiliary compartment can be supplied with 1, 2 or 3 VTs, and can be connected to bus or line, as required for a given application. The VTs assembly is located behind a fixed bolted panel, and provided with mechanism for

moving it between connected and disconnected position. The VT assembly is interlocked with the fixed bolted panel such that the panel cannot be removed unless the VTs are withdrawn to disconnected position. A shutter assembly covers the primary stabs when VTs are withdrawn to disconnected position. A mechanism is also provided to automatically discharge VT primary fuses as the VTs are withdrawn from connected to disconnected position.

- Ring type current transformers are installed over bus or line side primary insulating bushings, located behind the steel shutters, in the breaker compartment. In this design, the CTs are easily accessible from the front, after removal of the circuit breaker. The front accessibility permits adding or changing the CTs when the equipment is de-energized, but without removal of high-voltage joints or primary insulation. The design allows installations of two sets of standard or one set of high accuracy CTs on each side of the circuit breaker.

### About:

The ADVAC Medium Voltage Mechanical Vacuum Circuit Breaker series is a complete line of IEEE-rated vacuum circuit breakers with a spring-charged mechanism and three position electric racking, offering customers the advantages of the latest technology with a modular design that is easily maintainable.

### Help Keep Personnel Safe:

- Safety and protection of personnel and equipment with enclosed mechanism housing and embedded pole technology.
- Roll-on-floor (ROF) caster design offers ease of use.
- Three position remote motorized racking options available.

### Protect Your Assets:

- Built-in truck interlocks for a compact and robust solution.
- Maintenance free embedded pole design helps protect vacuum interrupters from contamination, moisture, damage, and improving tracking resistance.

### Optimizing Investments:

- Lowest power consumption accessories for reduced battery bank systems.
- The integrated racking mechanism (truck) is designed to 180 ft lbs of torque for increased reliability and reduced maintenance costs.
- Highest quality and short lead times through automated production process.

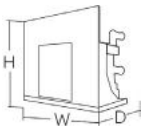

### Technical characteristic

Circuit breaker	AMVAC 05			AMVAC 08				
Rated insulation voltage	[kV]	4.76			8.25			
Impulse withstand voltage	[kV]	60			95			
Rated frequency	[Hz]	60			60			
Execution		Fixed / ADVANCE / Safegear			Fixed / ADVANCE / Safegear			
Rated normal current (40 °C)	[A]	1200	2000	3000	1200	2000	3000	
		25	25	25				
Rated breaking capacity and rated short-time withstand current (3s)	[kA]	32	32	32	40	40	40	
		40	40	40				
		50	50	50				
Making capacity	[kA]	65	65	65	140	140	140	
		82	82	82				
		104	104	104				
		130	130	130				
Operation sequence		[O - 0.3 s - CO - 3 min - CO]			[O - 0.3 s - CO - 3 min - CO]			
Interrupting time	[ms]	50-83	50-83	50-83	50-83	50-83	50-83	
Closing time	[ms]	35 ... 60	35 ... 60	35 ... 60	35 ... 60	35 ... 60	35 ... 60	
Overall dimensions (fixed version)		H	18.68 ...	23.68 ...	23.68 ...	23.17 ...	23.68 ...	23.68 ...
		[inches]	25.1	26.4	27	25.1	26.2	27
		W	27.55 ...	27.55 ...	29.53 ...	27.56 ...	29.53 ...	29.53 ...
		[inches]	31	31	31	31	31	31
		D	15.16 ...	15.16 ...	15.93 ...	15.16 ...	15.93 ...	15.93 ...
		[inches]	26	26	26.1	25.9	26	23.1
Weight	[lb]	410	410	420	410	420	460	

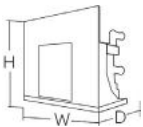
Circuit breaker	AMVAC 15			AMVAC 27				
Rated insulation voltage	[kV]	15			27			
Impulse withstand voltage	[kV]	95			125			
Rated frequency	[Hz]	60			60			
Execution		Fixed / ADVANCE / Safegear / Safegear HD			Fixed / ADVANCE			
Rated normal current (40 °C)	[A]	1200	2000	3000	1200	2000		
		25	25	25	16	16		
Rated breaking capacity and rated short-circuit withstand current (3s)	[kA]	32	32	32	25	25		
		40	40	40	-	-		
		50	50	50	-	-		
Making capacity	[kA]	65	65	65	42	42		
		82	82	82	65	65		
		104	104	104	-	-		
		130	130	130	-	-		
Operation sequence		[O - 0.3 s - CO - 3 min - CO]			[O - 0.3 s - CO - 3 min - CO]			
Interrupting time	[ms]	50	50	50	83	83		
Closing time	[ms]	35 ... 60	35 ... 60	35 ... 60	35 ... 60	35 ... 60		
Overall dimensions (fixed version)		H	18.68 ...	23.68 ...	23.68 ...	24.72 ...	25.47 ...	
		[inches]	25.1	26.4	27	26.8	27.4	
		W	27.55 ...	27.55 ...	29.53 ...	29.53 ...	29.53 ...	
		[inches]	31	31	31	31	31	
		D	15.16 ...	15.16 ...	15.93 ...	15.93 ...	15.93 ...	
		[inches]	26	26	26.1	25.9	26.1	
Weight	[lb]	360 ...	410 ...	430 ...	-	-		
		510	510	510	410	410		

\* For more details check the overall dimension





# PowerClad

5kV Metal-Clad  
Medium Voltage Switchgear



## Standard Metal-Clad Switchgear Assembly Ratings

PowerClad-W metal-clad switchgear is available for application at voltages up to 5kV, 50 or 60 Hz. Refer to the table below for complete list of available ratings.

**Table 5.6-1.** Standard VCP-W (Non-Arc-Resistant) metal-clad Switchgear Ratings Per IEEE C37.20.2-2015 ab

Rated Maximum Voltage	(Ref.) Rated Voltage Range Factor K	(Ref.) Rated Short-Circuit Current I	Insulation Level		Rated Main Bus Continuous Current ③④	Rated Short-Time Short-Circuit Current Withstand (2-Second)	Rated Momentary Short-Circuit Current Withstand (10-Cycle) (167 ms)	
			Power Frequency Withstand Voltage, 60 Hz, 1 Minute	Lightning Impulse Withstand Voltage [LIWV] (BIL)			K*I ⑤	2.7 *K*I ⑥
kV rms		kA rms	kV rms	kV Peak	Amperes	kA rms Sym.	kA Crest	kA rms Asym.
4.76	1	25	19	60	1200, 2000, 3000, 4000	25	68	40
	1.24	29			1200, 2000, 3000, 4000	36	97	58
	1	40			1200, 2000, 3000, 4000	40	108	64
	1.19	41			1200, 2000, 3000, 4000	49	132	78
	1	50			1200, 2000, 3000, 4000	50	135	80
	1	63			1200, 2000, 3000, 4000	63	170	101
8.25	1.25	33	36	95	1200, 2000, 3000, 4000	41	111	66
	1	50			1200, 2000, 3000, 4000	50	135	80
15	1.3	18	36	95	1200, 2000, 3000, 4000	23	62	37
	1	25			1200, 2000, 3000, 4000	25	68	40
	1.3	28			1200, 2000, 3000, 4000	36	97	58
	1	40			1200, 2000, 3000, 4000	40	108	64
	1.3	37			1200, 2000, 3000, 4000	48	130	77
	1	50			1200, 2000, 3000, 4000	50	135	80
27	1	16	60	125	1200, 2000, 2500, 2700	16	43	26
	1	22			1200, 2000, 2500, 2700	22	60	35
	1	25			1200, 2000, 2500, 2700	25	68	40
	1	31.5			1200, 2000, 2500, 2700	31.5	85	51
	1	40			1200, 2000, 2500, 2700	40	108	64
	1	63			1200, 2000, 2500, 2700	63	170	101
38	1	16	80	150 ⑧	1200, 2000, 2500, 3000	16	43	26
	1	25			1200, 2000, 2500, 3000	25	68	40
	1	31.5			1200, 2000, 2500, 3000	31.5	85	51
	1.65	23			1200, 2000, 2500, 3000	35	95	56
	1	40			1200, 2000, 2500, 3000	40	108	64

- The switchgear assembly is designed for use with type VCP-W, VCP-WC and VCP-WG circuit breakers. However, please note that certain VCP-WC circuit breakers may have higher capabilities than required by ANSI standards. In such cases, switchgear assembly ratings as given in this table will apply.
- Switchgear assemblies can be supplied with UL/CSA label. Contact Spike Electric Controls for availability.
- Circuit breaker requires forced air cooling to carry 4000 A at 4.76, 8.25 and 15kV, and 3000 A at 5kV.
- 27kV 2500 A and 2700 A main bus ratings are available in two-high design configurations only.
- Please note that use of certain current transformers (for example, bar type CTs) and protective devices may limit the duration to a value less than 2 seconds.
- These values exceed 2.6\*K\*I required by IEEE C37.20.2-2015.
- These values exceed 1.55\*K\*I required by IEEE C37.20.2-2015.
- This is a standard IEEE C37.20.2 rating for 5kV Class of switchgear.

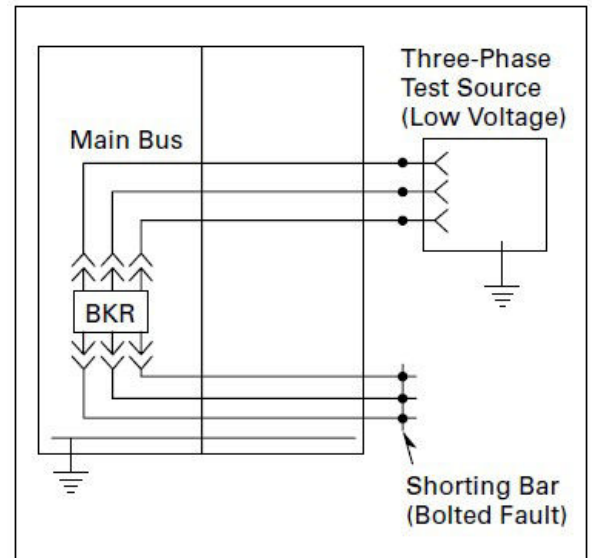

Metal-clad Switchgear Short-Circuit and Momentary Withstand Tests



# PowerClad

5kV Metal-Clad  
Medium Voltage Switchgear



## Unusual & Usual Service Conditions:

### Unusual Service Conditions:

Applications of metal-clad switchgear at other than usual altitude or temperature, or where solar radiation is significant, require special consideration. Other unusual service conditions that may affect design and application include:

- Exposure to salt air, hot or humid climate, excessive dust, dripping water, falling dirt, or other similar conditions.
- Unusual transportation or storage conditions.
- Switchgear assemblies when used as the service disconnecting means when used as a means of service disconnection.
- Installations accessible to the general public.
- Exposure to seismic shock.
- Exposure to nuclear radiation.

### Usual Service Conditions:

Usual service conditions for operation of metal-clad switchgear are as follows:

- Altitude does not exceed 3300 feet(1000 m).
- Ambient temperature within the limits of -30 °C and +40 °C (-22 °F and +104 °F).
- The effect of solar radiation is not significant.

## Applications:

### Above 3300 Ft (1006m):

Equipment utilizing sealed interrupting devices (such as vacuum interrupters) does not require derating of rated maximum voltage. The rated one minute power frequency withstand voltage, the impulse withstand voltage and the continuous current rating must be multiplied by the appropriate correction factor in Table 5.6-4 to obtain modified ratings that must equal or exceed the application requirements.

Table 5.6-2. Derating Factors

Interrupting Current Derating Factors			
50 Hz	25 Hz	16 Hz	12 Hz
None	0.65	0.52	0.45

Note: Intermediate values may be obtained by interpolation.

### Above or Below 40 °C Ambient:

Refer to ANSI C37.20.2, Section 8.4 for load current carrying capabilities under various conditions of ambient temperature and load.

## At Frequencies Less Than 60 Hz:

Rated Short-Circuit Current Based on series of actual tests performed on Type VCP-W circuit breakers and analysis of these test data and physics of vacuum interrupters, it has been found that the current interruption limit for Type VCP-W circuit breakers is proportional to the square root of the frequency. Table 5.6-2 provides derating factors, which must be applied to breaker interrupting current at various frequencies.

## Rated

### Short-Time & Close & Latch Currents:

No derating is required for short time and close and latch current at lower frequency.

### Continuous Current:

Because the effective resistance of circuit conductors is less at lower frequency, continuous current through the circuit can be increased somewhat. Table 5.6-3 provides nominal current rating for VCP-W breakers when operated at frequencies below 60 Hz.

Table 5.6-3. Current Ratings

Rated Continuous Current at 60 Hz	Nominal Current at Frequency Below 60 Hz			
	50 Hz	25 Hz	16 Hz	12 Hz
1200 A	1243	1410	1519	1589
2000 A	2075	2374	2573	2703
3000 A	3119	3597	3923	4139



**Green Energy Efficient:** The PowerClad 5kV Metal-Clad MV Switchgear is designed with energy efficiency at its core, incorporating several features that minimize power usage and enhance sustainability. It employs advanced ABB vacuum circuit breaker technology, renowned for its low power consumption, which significantly reduces the overall energy requirements of the system. Additionally, the switchgear is equipped with accessories that are specifically designed for the lowest possible power consumption, drastically cutting down on the energy used by battery bank systems. Its integrated racking mechanism, which uses only 180 ft-lbs of torque, optimizes mechanical efficiency and lowers the energy needed for operation. Furthermore, the switchgear's 75% reduction in power consumption through its innovative accessories underscores its commitment to energy efficiency, promoting a reduced environmental footprint while maintaining high performance in electrical distribution.



# PowerClad

5kV Metal-Clad  
Medium Voltage Switchgear



## Limited Warranty for ABB Medium Voltage Circuit Breakers, Protection Relays, and Components

### 1. Overview

Spike Electric Controls, in collaboration with ABB, provides a comprehensive **dual warranty** program for ABB medium voltage circuit breakers, protection relays, and related components. This program extends the standard warranty coverage offered by ABB to ensure superior protection for industrial applications.

### 2. Warranty Coverage

#### Medium Voltage Circuit Breakers

- **5-Year Limited Warranty** Spike Electric Controls offers an extended **5-year limited warranty** on all ABB medium voltage circuit breakers. This warranty covers defects in materials and workmanship for five years from the Factory Acceptance Date, providing extended protection beyond the typical industry standard of 1 year.

#### Protection Relays and Components

- **1-Year Limited Warranty** ABB protection relays, contactors, and other components purchased through Spike Electric Controls are covered under a **1-year limited warranty** for defects in materials and workmanship.

#### Extended Warranty Options

Customers may purchase extended warranty periods beyond the standard coverage for certain components. For information on extended warranties, please contact Spike Electric Controls for available options and pricing.

### 3. Preventive Maintenance (PM) Recommendations

Regular preventive maintenance (PM) is crucial to ensuring the long-term reliability and safety of your medium voltage equipment. It is recommended that PM be performed at least **annually or bi-annually**, depending on environmental conditions and equipment usage. According to **ANSI/NETA and IEEE** guidelines, medium voltage switchgear and circuit breakers should undergo visual and mechanical inspections, cleaning, lubrication, and electrical testing at least **every 1 to 3 years**, depending on operational demands and environmental factors.

To maximize your equipment's lifespan and maintain warranty validity, Spike Electric Controls strongly recommends utilizing Spike Field Services for regular PM, at a minimum of twice per year, particularly in harsh or high-usage environments.

### 4. Exclusions and Limitations

This warranty does not cover:

- Normal wear and tear or cosmetic damage.
- Damage or failure resulting from improper installation, unauthorized repairs, misuse, or neglect.
- Environmental factors outside the product's specifications, such as extreme weather conditions, fire, or water damage.
- Damage caused by electrical surges, power irregularities, or improper maintenance not performed by authorized personnel.

### 5. Warranty Claim Process

To initiate a warranty claim for Switch Gear or Switchgear Components, please follow these steps:

1. Contact Spike Electric Controls: <https://new.abb.com/channel-partners/partner-details/G10780907>
2. Provide the following information:
  - Product model and serial number.
  - Detailed description of the defect or failure.
  - Proof of installation and the installation date.
3. Spike Electric will coordinate with ABB to assess the issue. If the product is found to be defective under the warranty terms, it will be repaired or replaced at no cost to the customer.

### 6. Customer Support

For additional support or questions regarding your warranty, please contact Spike Electric Controls at:

Phone: 1.844.279.8295

Email: [switchgear@spikeelectric.com](mailto:switchgear@spikeelectric.com)



# PowerClad

5kV Metal-Clad  
Medium Voltage Switchgear



## Five Year Warranty

### AMVAC™ magnetically actuated circuit breaker

A five year comprehensive warranty is available on the complete breaker and breaker truck assembly, with 24 hours / 7 days-a-week customer service.

The AMVAC™ breaker is truly the next generation in medium voltage vacuum circuit breaker technology. ABB is the first to combine the unique benefits of embedded vacuum interrupter technology with a magnetic actuator designed to reduce operating costs and increase reliability.

Using a flux-shifting device with integral permanent magnets, the AMVAC mechanism has only one moving part. With simple open and close coils, an electronic controller and capacitors for energy storage, the AMVAC circuit breaker meets or exceeds ANSI mechanical and load operation requirements.

### Low maintenance = reduced operating costs

- No maintenance required on the magnetic actuator
- Closing and tripping is a current limited pulse – eliminates failed trip coils

### Significantly less moving parts = reliability and safety

- Simple magnetic actuator with one moving part
- Elimination of close and trip coils, motors, cams, and linkages and the associated spare parts inventory
- Increased safety by eliminating maintenance on mechanically charged components, coils, and motors

The AMVAC circuit breaker utilizes state-of-the-art magnetic actuation technology

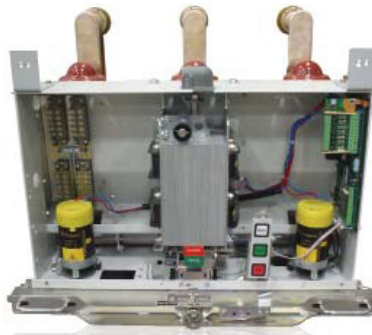

### Durable design = longer life

- High dielectric strength with embedded vacuum interrupters in solid material insulation

ABB stands ready to work with you to supplement this product offering with technical application experts, spare parts, training and support services intended to reduce your total cost of ownership.

Maintenance free vacuum interrupter and current carrying parts in one embedded assembly





**BUY AMERICAN**



## **BUY AMERICAN ACT CERTIFICATE**

**ATTENTION:** Engineers, Channel Partners, Building Officials, and Inspectors

**SUBJECT:** U.S.A Manufacturing

Spike Electric Controls is committed to American craftsmanship. Every product we offer is manufactured within the United States using raw materials sourced from trusted U.S. steel & copper mills. This commitment not only ensures superior quality but also aligns with the principles of the Buy American Act.

We understand the importance of transparency and are always open to discussing our manufacturing process or the origins of our materials. For any questions or additional information, please feel free to contact me.

Thank you,

Cole Attaway, CEO

Mobile: 832.720.4598

Email: [cole@spikeelectric.com](mailto:cole@spikeelectric.com)

5914 E. Sam Houston Pkwy, Houston TX 77034



# PowerClad

5kV Metal-Clad  
Medium Voltage Switchgear



Spike Electric Controls  
5914 E. Sam Houston Pkwy S.  
Houston TX 77034

Toll Free 1.844.279.8295 • Local Factory Support 832.243.5372 • Fax 832.569.5645  
sales@spikeelectric.com spikeelectric.com

Copyright © 2024 Spike Electric Controls

Valued Partner Acknowledgment Statement: Spike Electric Controls has partnered with ABB as a Value Add Partner, blending ABB's cutting-edge technology with our expertise in electrical solutions to elevate industry standards. This partnership aims to globally enhance system efficiency, reliability, and sustainability, delivering sophisticated electrification solutions to our customers. Additionally, this alliance includes dual branding of our Switchgear products and extends ABB's warranties through Spike's comprehensive Switchgear solutions, ensuring quality and reliability.