



SAFE SYNC

AUTOMATIC TRANSFER SWITCH

Medium 5kV & 15kV Voltage Power Transfer Switches

Spike Electric Controls presents innovative solutions that safeguard power integrity - from the conceptual stage right through to deployment, initiation, and sustained usage: all-encompassing protection for uninterrupted energy.

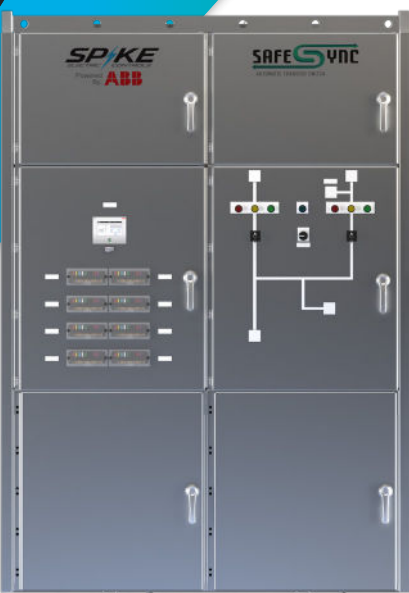

Valued Partner Acknowledgment Statement: Spike Electric Controls has partnered with ABB as a Value Add Partner, blending ABB's cutting-edge technology with our expertise in electrical solutions to elevate industry standards. This partnership aims to globally enhance system efficiency, reliability, and sustainability, delivering sophisticated electrification solutions to our customers. Additionally, this alliance includes dual branding of our Switchgear products and extends ABB's warranties through Spike's comprehensive Switchgear solutions, ensuring quality and reliability.



Microprocessor-Driven Control Center:

At the heart of the Safe Sync SERIES is our state-of-the-art microprocessor-driven Control Center, expertly designed to manage breaker operations, seamlessly transitioning critical loads between power sources.

Encompassing two voltage classifications - 15 kV and 5 kV - our Medium Voltage Transfer Switch can be tailored with a variety of accessories and unique specifications to fulfill distinct installation needs.

Switch mode variants available are:

- Open transition
- Delayed transition
- Closed transition

Our assemblies boast a robust metal-clad design, distinct control barriers, easily removable circuit breakers, and high-quality voltage transformers, ensuring optimal performance across the stipulated amperage and voltage ranges.

Safe Sync Series Medium 5kv & 15kv Voltage Power Transfer Switches

About Safe Sync:

In an electrified world, the steadiness, caliber, and dependability of energy not only influence everyday life but are paramount for safety, operational excellence, and fiscal prosperity.

Spike Electric Controls presents innovative solutions that safeguard power integrity - from the conceptual stage right through to deployment, initiation, and sustained usage: all-encompassing protection for uninterrupted energy.

Our Safe Sync series has been meticulously crafted to turn potential energy disruptions into unwavering confidence.

Offering a diverse range of configurations, supplementary features, and transfer mechanisms such as prompt, deferred, sealed, and gentle load transitions, the Spike Electric Safe Sync SERIES assures performance that meets and even exceeds industry standards and is UL 1008A compliant.



Applications:

- Data Management Hubs
- Medical Institutions
- Telecommunication Hubs
- Industrial Estates
- Petrochemical Plants
- Production Facilities
- Continuous Operations
- Consumer Business Centers
- Research Laboratories
- Educational Campuses
- Municipal Utilities

Certifications:

We pride ourselves on meeting and surpassing the following industry benchmarks:

- ANSI/IEEE C37.20.2 – Standard for Metal-Clad Switchgear
- ANSI/NEMA C37.55 – Medium Voltage Metal-Clad Assemblies – Testing & Conformance Procedures

Below is a synopsis of the diverse voltage, current, and interrupt class ratings on offer:

Spike Electric Safe Sync SERIES 1200 Amp Medium Voltage Power Transfer Switch

Voltage Classes	Interrupt Classes (kA Symm.)	Rated Current (A)	Construction Details
15 KV	25, 40 kA, 50 kA	1200 Amps	Metal-Clad Switchgear adhering to ANSI C37.20.2, UL 1008A listed, featuring draw-out vacuum circuit breakers and high-caliber transformers
5 KV	40 kA, 50 kA	1200 Amps	Metal-Clad Switchgear adhering to ANSI C37.20.2, UL 1008A listed, featuring draw-out vacuum circuit breakers and high-caliber transformers

The Spike Electric Safe Sync SERIES embodies paramount defense, unwavering reliability, and secure maintenance. Our strict adherence to industry standards ensures:

- UL Compliance
- ANSI/IEEE C37.20.2 Benchmark for Metal-Clad Switchgear

Rated for optimal performance at either 5 kV or 15 kV, the Medium Voltage Power Transfer Switch boasts a range from 1200 up to 3000 amperes. As for the interrupt capacity, users can select from the 25, 40, or 50 kA symmetrical class options.

Our base medium voltage transfer switch structure is segmented into two to three vertical sections based on the current rating. Supplementary features, such as expansive metering or relaying, could necessitate additional sections. The fundamental configuration for a 1200 ampere switch integrates a minimum of two sections, while the 2000 or 3000 ampere versions encompass at least three sections. The combined sections cater to specific needs - be it seismic certifications, fortified outdoor casings, or other unique prerequisites, tailoring each assembly to the client's exact specifications.

Construction:

Prominent components and attributes encompass:

- Safe Sync Series Advanced Control Center
- Slide-Out, Shuttered Vacuum Circuit Breakers with Optional Protection Systems:
- A Standard Source VCB for the Transfer Switch
- A Backup Source VCB for the Transfer Switch
- Dual Standard Source Fused Slide-Out Voltage Transformers (Configured in WYE-WYE)
- Dual Backup Source Fused Slide-Out Voltage Transformers (Configured in WYE-WYE)



- Medium Voltage shielded copper bus bar 15kV Bus Boot boots for splices and cable connection points
- Defensive barricades in line with ANSI C37.20.2 and UL 1008A to segregate primary components.
- SIS-type control wiring enhanced with enduring printed markers directly on the insulation layer

A seamlessly unified multi-section metal-clad framework



Codes & Regulations:

- UL 1008A Accredited – Benchmark for Medium Voltage Transfer Switches
- National Electrical Guidelines (ANSI/NFPA 70)
- Article 517 – Medical Care Establishments
- Article 700 – Urgent Power Systems
- Article 701 – Mandated Backup Systems
- Article 702 – Elective Backup Systems
- Article 708 – Vital Operations Power Frameworks



Certification Highlights:

Earthquake Resistance - readily obtainable upon initiation of order

Arc Safety Provisions:

Features aimed at arc safety can encompass arc-protective design and specialized arc detection mechanisms.

Switch Control Unit:

Our Safe Sync Control Center, which epitomizes excellence in directing both low and medium voltage switches, draws upon decades of groundbreaking power transfer insights and expertise.



Circuit Breaker Dynamics:

These circuit breakers overshadow contactors in terms of reliability and ease of upkeep. Each breaker houses three distinct vacuum interrupters equipped with an embedded contact wear gap monitor. Built-in stored energy components ensure swift fault isolation and interruption. Their design promises secure inspections and straightforward maintenance. Both Standard Source and Backup Source breakers are swappable, maintaining uniform ratings and layout. Energy storage facets cover both electric motor recharging and a manual charging lever.

Instrumentation Transformers:

This includes Current Transformers (CT) and Voltage Transformers (VT, also known as Potential Transformers - PT) that measure electrical flow and voltage.

The conventional design features ANSI relay class transformers crafted as per ANSI C57.13 to guarantee uniform and dependable operations. Further enhancements like grounded carriage-mounts ensure secure maintenance, along with fuses for circuit safety.

Customized requirements, be it revenue-grade instruments, testing blocks, or added safety relays, can be integrated seamlessly.

Core Model Specifications & Design

Features:

Feature	5 kV / 15 kV (1200 A)	5 kV / 15 kV (2000 A / 3000 A)
Sections (Minimum Count)	2	3
Standard NEMA 1 Sizing	36"Wx92"Dx95"H	36"Wx92"Dx95"H
UL 1008A Compliance	Yes	Yes
ANSI C37.20.2	Yes	Yes
Seismic Certification	On Demand	Yes
Insulated Bus	Yes	Yes
Cable Blockers	Yes	Yes
11 Gauge Steel (Exterior Panels)	Yes	Yes
Slide-Out Breakers	Yes	Yes
Auto Shutters	Yes	Yes
Earthed Dividers	Yes	Yes
Electrostatic Powder Coating	Yes	Yes
Distribution Potential	Yes	Yes
Safety Relays Option	Yes	Yes
NEMA 3R Non-Walk-In Variant	Yes	Yes

Transition Options & Control Modes

Open Transition Transfer Switching:

Safe Sync allows for "non-synchronized" transfer if the preferred source is deemed "unstable" and the alternate source requires time come on-line. Additionally, if conditions require upstream/downstream protective actions to process before aligning loads to the alternate source.

Delayed Transition Transfer Switching:

Safe Sync allows for "non-synchronized" transfer if conditions require controlled transfer of energized loads that can withstand a short loss and return of power such as non-rotational loads, VFD, auto-restart load centers.

Closed Transition Transfer Switching:

Safe Sync allows for "synchronized" transfer if the conditions allow for safe, momentary parallel operations of available sources. Available communication protocols provide seamless integration with generator control systems to allow non-interrupted service for controlled switching evolutions.





User Control Modes:

Automatic & Manual: The mode selector switch empowers users to toggle between automated and manual control effortlessly. The options range from open, delayed, to closed transitions, inclusive of the soft load control. For enhanced safety, electrically safeguarded manual controls are embedded on the front panel for supervised operations.

Breaker Control & Mode Selector Switches:

- Enables users to manually trip or close the breaker, irrespective of the mode.
- Features indicators for easy understanding: Red for Closed, Green for Open, and Amber for Tripped.
- The embedded electrical interlocks ensure that there's no chance of simultaneous activation, guaranteeing utmost safety.

Controller & Protection Relay:

The Safe Sync MV Transfer Switch, featuring ABB's REX640 Relay, functions both as a controller and a protection relay. This integration reduces potential failure points and streamlines inventory management. It cuts down the need for stocking different control components, leading to more efficient and cost-effective maintenance, especially when replacing a controller or relay.



Green Energy Efficient:

As the world pivots towards renewable energy, the MVTS of the future must effortlessly integrate with sources like solar and wind. Spike Electric Controls is leading the charge, innovating MVTS solutions that bridge conventional and renewable power seamlessly.

The Impetus for Green Integration

- **Harnessing Renewables:** The future MVTS will seamlessly integrate with renewable energy sources, acting as bridges between conventional and green power.
- **Smart Grids and MVTS:** By aligning with evolving smart grid technologies, future MVTS, especially those of Spike Electric's caliber, will become even more central to sustainable power management.



NOTE:
SOME PANELS HIDDEN FOR CLARITY

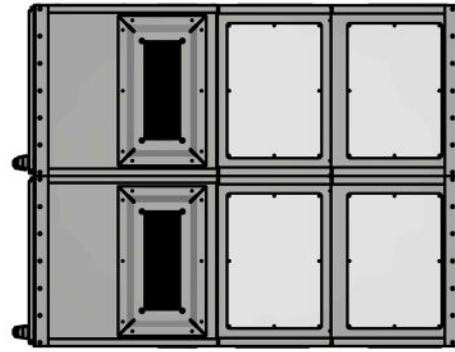

TOP VIEW

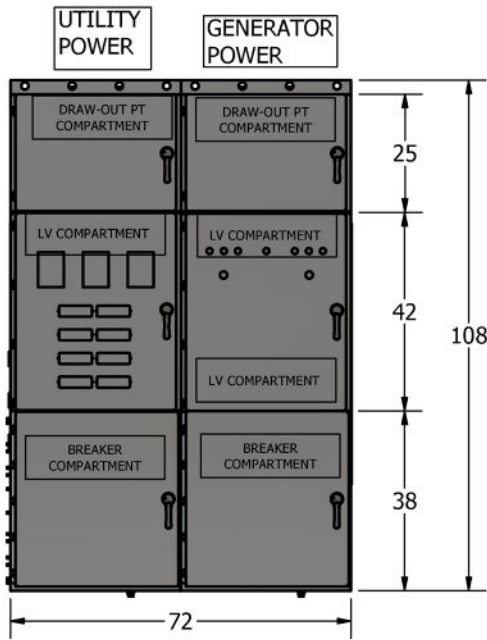

FRONT VIEW

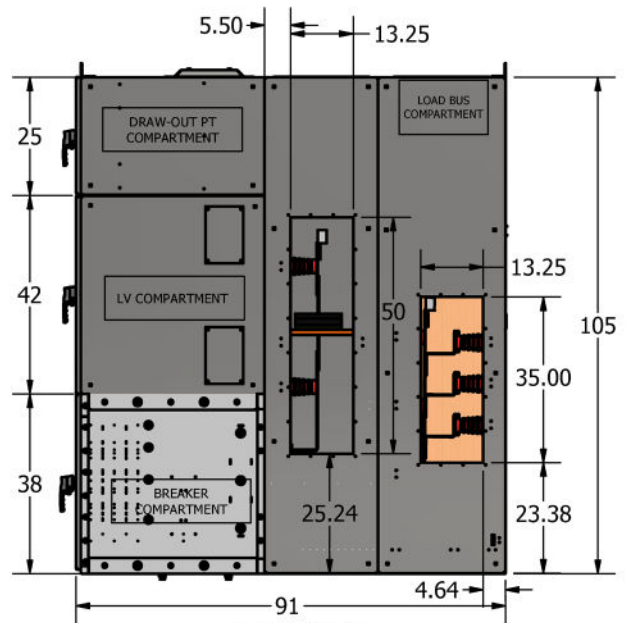

SIDE VIEW

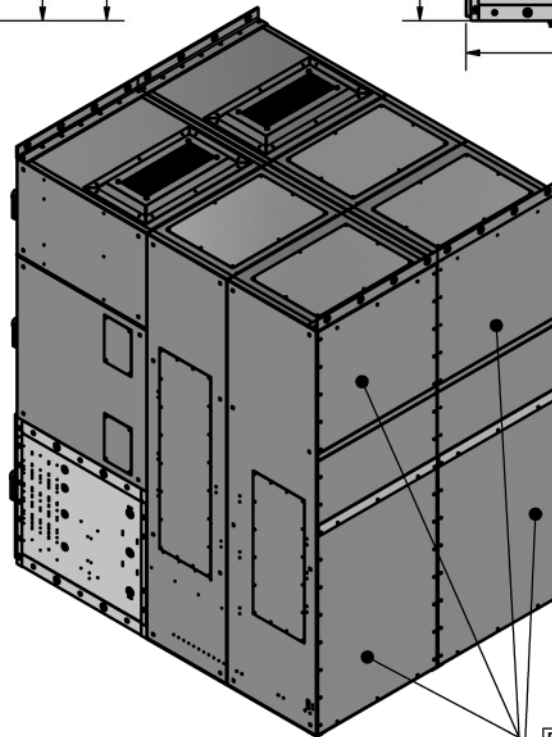

ISO VIEW

REMOVABLE
REAR COVERS

AMVAC™ 5/15/27 kV ANSI Magnetic Mechanism Vacuum Circuit Breaker

General Overview:

The AMVAC breaker is a magnetically actuated and latched breaker capable of a high number of operations due to its simplified design. Fully compliant with IEEE Standards C37.04, C37.06 and C37.09, the AMVAC breaker is a great fit for many applications.



Features:

- Mechanical operations counter
- Optional roll-on-floor design
- Open, closed, ready/not ready lights and pushbuttons
- Maintenance-free magnetic actuator

Available AMVAC breaker ratings

Voltage class	Nominal voltages	Continuous current	Short circuit/ with-stand (2 sec)	Close and latch	BIL (lightning im- pulse withstand)	Low frequency withstand (Hi-Pot)
kV	kV	A	kA, rms	kA, peak	kV, crest	kV, rms
5	2.4, 4.16, 4.8	1200, 2000, 3000	25	65	60	19
			31.5	82		
			40	104		
			50	130		
8.25	4.8, 6.9, 7.2	1200, 2000, 3000	40	104	95	36
			25	65		
			31.5	82		
			40	104		
15	6.9, 7.2, 8.4, 11, 12, 12.47, 13.2, 13.8, 14.4	1200, 2000, 3000	50	130	95	36
			16	42		
			25	65		
			27	125		

Construction:

Magnetic Actuator:

Introduced in 1997, the bi-stable magnetic actuator is used in many ABB products, including the AMVAC breaker. Due to its simple design, no maintenance on the actuator is necessary for the lifetime of the product.

The magnetic actuator operates on the principle of shifting magnetic flux and is latched into one of the stable positions by rare-earth magnets which require no power.

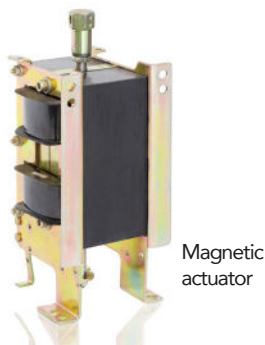

Magnetic actuator

Vacuum Interrupters:

ABB vacuum interrupters (VIs) are embedded in a solid insulation material to protect the VIs from collecting dust or moisture and from accidental bumps. The solid insulation also improves tracking resistance making ABB circuit breakers some of the lightest available in the market. Because of the embedded design, these vacuum interrupters are maintenance-free for the life of the VI.



Vacuum interrupters

On-board Capacitors:

The on-board capacitors of the AMVAC breaker deliver the current needed for creation of magnetic fields within the mechanism thereby eliminating current draw and voltage drop from the battery bank for the substation.

For more information on the maintenance of the capacitors, please see the AMVAC Installation, Operation and Maintenance Manual.



On-board capacitors

AMVAC™ 5/15/27 kV ANSI Magnetic Mechanism Vacuum Circuit Breaker

Electronic Control Board:

The electronic control board technology for the AMVAC breaker provides improved reliability due to its self-monitoring functions and features. Featuring coil monitoring, sensor monitoring, optional under-voltage trip and optional energy failure trip, the AMVAC breaker is customizable for any application.

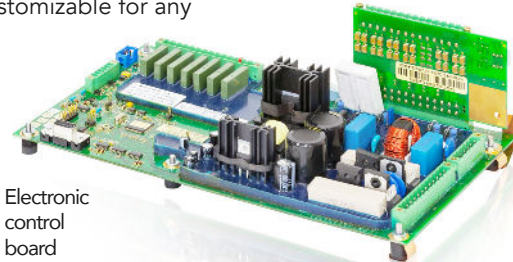

Electronic control board

By managing the 45 ms current limited pulse delivered to the mechanism by the on-board capacitors, the electronic control board eliminates one cause of common failures in typical spring mechanism breakers – the burning of trip and close coils.

Breaker Racking Truck:

ABB's breaker racking truck for switchgear is integral to the breaker itself in lieu of being inside the switchgear breaker cell. Rated for 180 foot-pounds of torque, the breaker racking truck exceeds the industry standard of 50-60 foot-pounds by a factor of three, greatly reducing the possibility of an over-torque condition.

The breaker racking truck is rated for 1000 rack in-rack out operations, exceeding the ANSI Standard of 500 operations.



Breaker lift truck

Capacitor Bank Switch Ratings

Voltage class kV	Continuous current A	Short circuit current kA	Capacitor switching ratings			
			Type	Notes		
5	1200	25	C0	25 A cable charging		
		31.5	C0	25 A cable charging		
		40	C0	25 A cable charging		
		50	C0	630 A back to back capacitor bank		
		2000	25	C0	25 A cable charging	
			31.5	C0	25 A cable charging	
	40		C0	630 A back to back capacitor bank		
	50		C0	630 A back to back capacitor bank		
	3000		25	C1	630 A back to back capacitor bank	
			31.5	C1	630 A back to back capacitor bank	
		40	C1	630 A back to back capacitor bank		
		50	C1	630 A back to back capacitor bank		
8.25		1200	40	C1	630 A back to back capacitor bank	
		2000	40	C1	630 A back to back capacitor bank	
	3000	40	C1	630 A back to back capacitor bank		
15	1200	25	C0	25 A cable charging		
		31.5		25 A cable charging		
		40	C1	630 A back to back capacitor bank		
		50	C1	1000 A back to back capacitor bank		
		2000	25		25 A cable charging	
			31.5		25 A cable charging	
	40		C1	630 A back to back capacitor bank		
	50		C1	1000 A back to back capacitor bank		
	3000		25	C1	630 A back to back capacitor bank	
			31.5	C1	630 A back to back capacitor bank	
		40	C1	630 A back to back capacitor bank		
		50	C1	1000 A back to back capacitor bank		
		27	1200	16	BTB	400 A back to back capacitor bank
				25	BTB	400 A back to back capacitor bank
	2000			16	BTB	400 A back to back capacitor bank
			25	BTB	400 A back to back capacitor bank	



AMVAC™ 5/15/27 kV ANSI Magnetic Mechanism Vacuum Circuit Breaker

Timing Characteristics:

Total interrupting time consists of opening time plus the time required for arc interruption. Total interrupt time is 50 ms or less for three cycle breakers and 83 ms or less for five cycle breakers.

Voltage class	Continuous current	Short circuit current	Interrupt time	Closing time
kV	A	kA	Cycles	ms
5	1200	25	3	45-60
		31.5	3	45-60
		40	5	45-60
		50	5	45-60
	2000	25	3	45-60
		31.5	3	45-60
		40	3	45-60
		50	5	45-60
	3000	25	3	45-60
		31.5	3	45-60
		40	3	45-60
		50	5	45-60
8.25	1200	40	3	45-60
	2000	40	3	45-60
	3000	40	3	45-60
15	1200	25	3	45-60
		31.5	3	45-60
		40	3	45-60
		50	3	45-60
	2000	25	3	45-60
		31.5	3	45-60
		40	3	45-60
		50	3	45-60
	3000	25	3	45-60
		31.5	3	45-60
		40	3	45-60
		50	3	45-60
27	1200	16	3	45-60
		25	3	45-60
	2000	16	3	45-60
		25	3	45-60





AMVAC™ 5/15/27 kV ANSI Magnetic Mechanism Vacuum Circuit Breaker

Mechanical Endurance Ratings:

Voltage class	Continuous current	Short circuit current	No load mechanical operations
kV	A	kA	
5	1200	25	10000
		31.5	10000
		40	10000
		50	10000
	2000	25	10000
		31.5	10000
		40	10000
		50	10000
	3000	25	10000
		31.5	10000
		40	10000
		50	10000
8.25	1200	40	10000
	2000	40	10000
	3000	40	10000
15	1200	25	10000
		31.5	10000
		40	10000
		50	10000
	2000	25	10000
		31.5	10000
		40	10000
		50	10000
	3000	25	10000
		31.5	10000
		40	10000
		50	10000
27	1200	16	10000
		25	10000
	2000	16	10000
			10000

Power Requirements and Auxiliary Switch Ratings

Power requirements

	Actuator driver
Standby	10 W
Capacitor charging	100 W
Trip/close	0.25 W

Auxiliary contacts

	Nominal control power voltage					
	24 Vdc	48 Vdc	125 Vdc	250 Vdc	120 Vac	240 Vac
Rated carrying current	10 A	10 A	10 A	10 A	10 A	10 A
Rated breaking current	10 A	7.6 A	4.4 A	1.8 A	2.6 A	2.3 A
Maximum breaking current	12 A	10 A	6 A	0 A	26 A	23 A



AMVAC™ 5/15/27 kV ANSI Magnetic Mechanism Vacuum Circuit Breaker

Dimensions and Weight:

Voltage class	Continuous current	Short circuit current	Height	Width	Depth	Weight
kV	A	kA	in	in	in	lb
5	1200	25	28	31	27	334
		31.5	28	31	27	334
		40	28	31	27	410
		50	28	31	27	410
	2000	25	28	31	27	419
		31.5	28	31	27	419
		40	28	31	27	419
		50	28	31	27	419
	3000	25	28	31	27	459
		31.5	28	31	27	459
		40	28	31	27	459
		50	28	31	27	459
8.25	1200	40	28	31	27	410
	2000	40	28	31	27	419
	3000	40	28	31	27	459
15	1200	25	28	31	27	334
		31.5	28	31	27	334
		40	28	31	27	410
		50	28	31	27	430
	2000	25	28	31	27	419
		31.5	28	31	27	419
		40	28	31	27	419
		50	28	31	27	430
	3000	25	28	31	27	459
		31.5	28	31	27	459
		40	28	31	27	459
		50	28	31	27	481
27	1200	16	30	31	27	410
		25	30	31	27	410
	2000	16	30	31	27	419
				30	31	27



AMVAC™ 5/15/27 kV ANSI Magnetic Mechanism Vacuum Circuit Breaker

Internal Diagram:

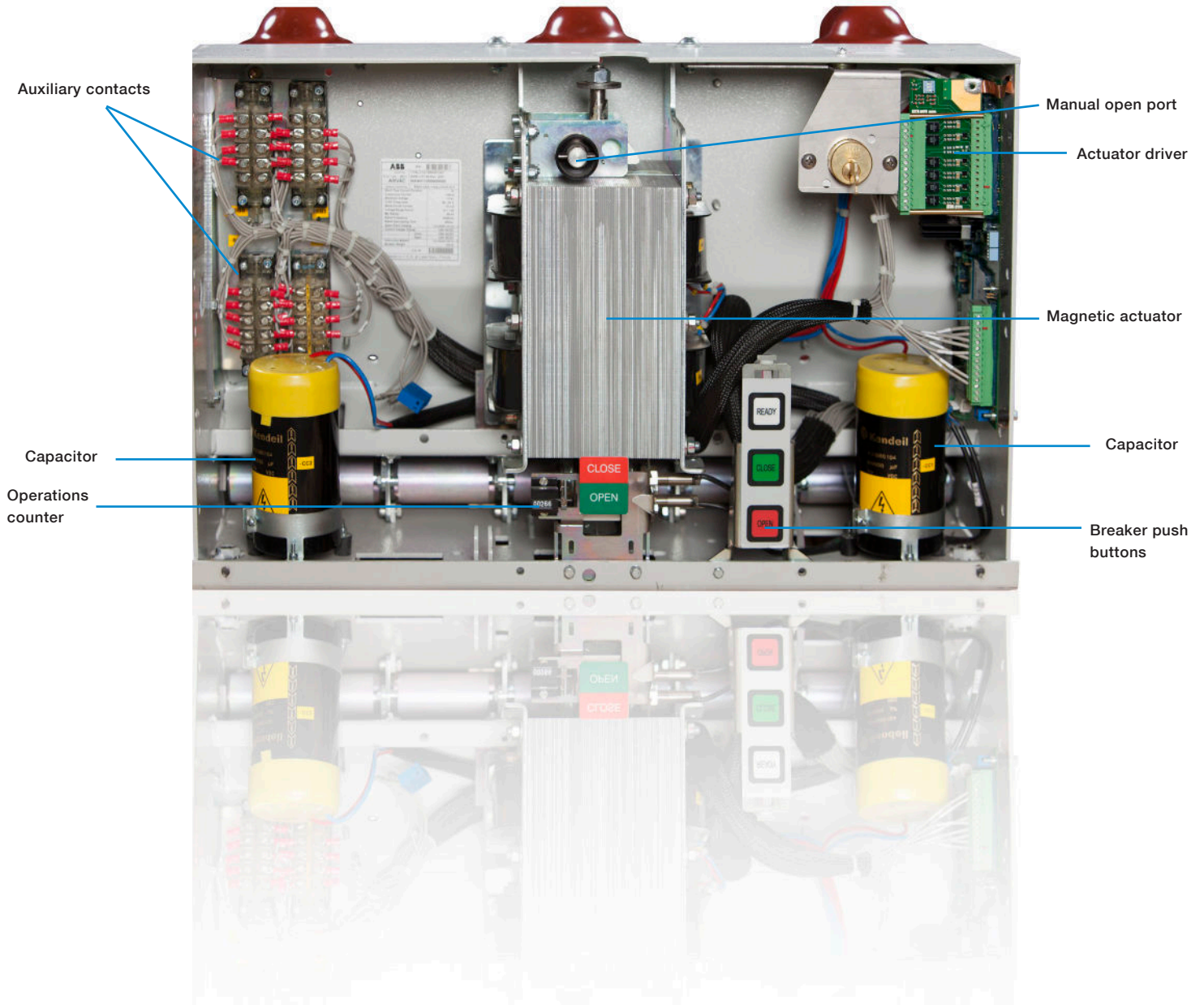

AMVAC™ 5/15/27 kV ANSI Magnetic Mechanism Vacuum Circuit Breaker

Outline Drawing:

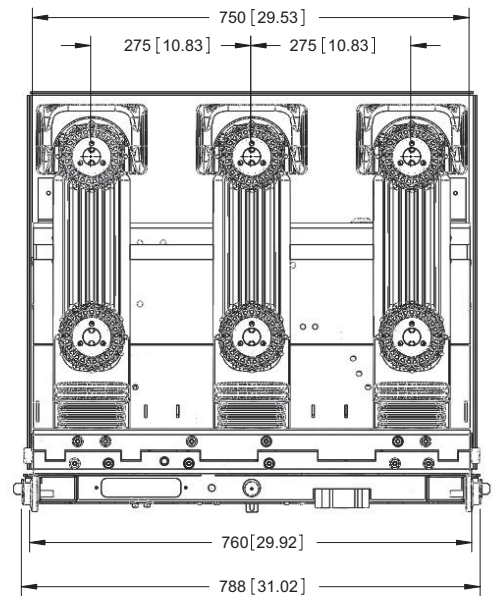
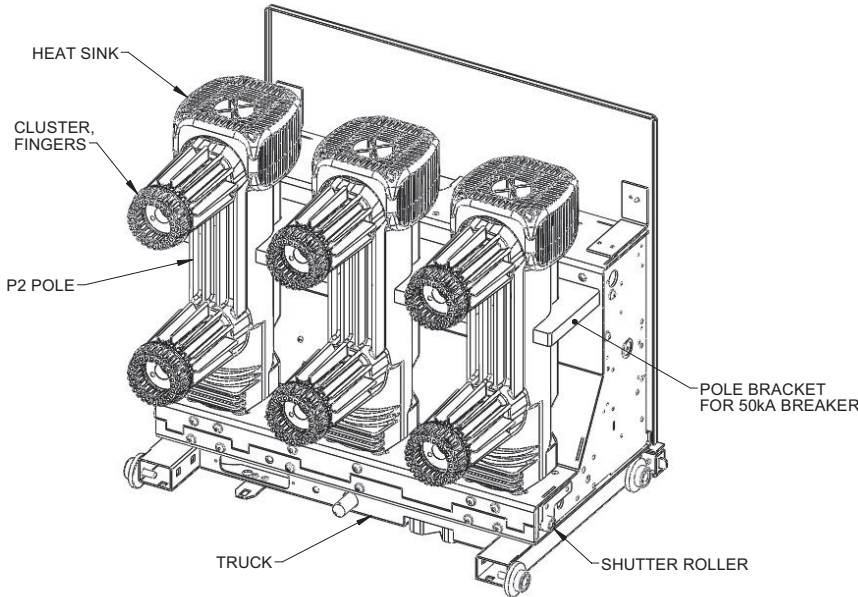
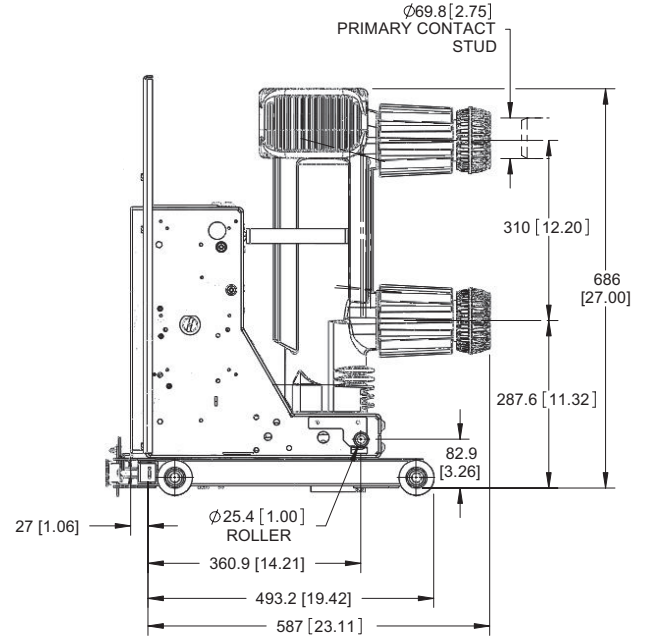
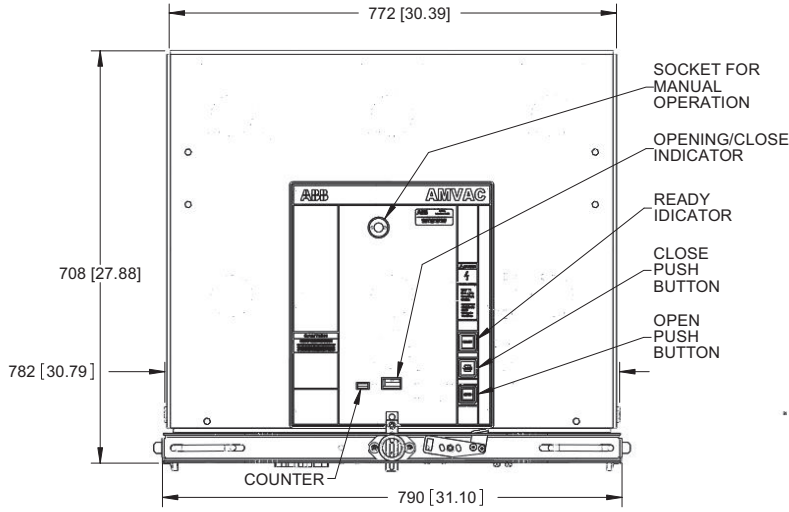

AMVAC™ 5/15/27 kV ANSI Magnetic Mechanism Vacuum Circuit Breaker

Schematic Drawing:

AMVAC circuit breakers are supplied with dual secondary disconnects, which includes 9 normally open “a” contacts and 8 normally closed “b” contacts.

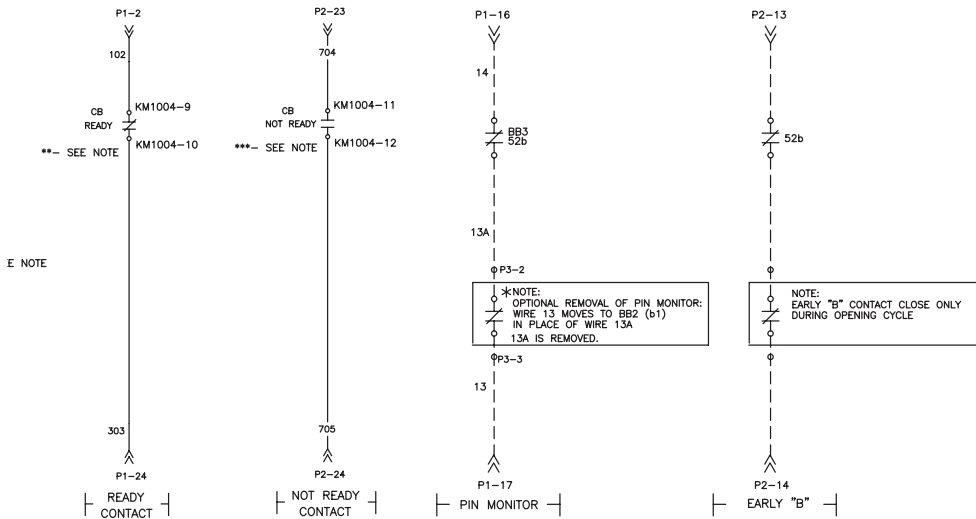
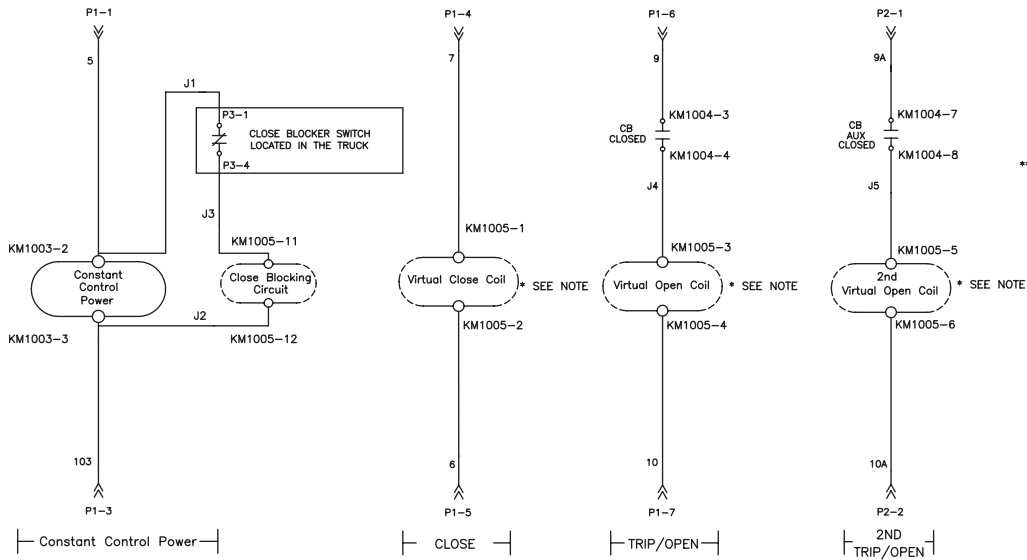



AMVAC™ magnetically actuated circuit breaker

Five year warranty

A five year comprehensive warranty is available on the complete breaker and breaker truck assembly, with 24 hours / 7 days-a-week customer service.

The AMVAC™ breaker is truly the next generation in medium voltage vacuum circuit breaker technology. ABB is the first to combine the unique benefits of embedded vacuum interrupter technology with a magnetic actuator designed to reduce operating costs and increase reliability.

Using a flux-shifting device with integral permanent magnets, the AMVAC mechanism has only one moving part. With simple open and close coils, an electronic controller and capacitors for energy storage, the AMVAC circuit breaker meets or exceeds ANSI mechanical and load operation requirements.



Low maintenance = reduced operating costs

- No maintenance required on the magnetic actuator
- Closing and tripping is a current limited pulse – eliminates failed trip coils



Significantly less moving parts = reliability and safety

- Simple magnetic actuator with one moving part
- Elimination of close and trip coils, motors, cams, and linkages and the associated spare parts inventory
- Increased safety by eliminating maintenance on mechanically charged components, coils, and motors

Durable design = longer life

- High dielectric strength with embedded vacuum interrupters in solid material insulation

ABB stands ready to work with you to supplement this product offering with technical application experts, spare parts, training and support services intended to reduce your total cost of ownership.



Protection and control REX640

Complete coverage for advanced power distribution and generation applications

Complete coverage for advanced power distribution and generation applications

Complete application coverage with one device for optimal flexibility and cost-effectiveness

Application package concept for maximum convenience and flexibility

Designed to support the increasing digitalization of substations

- Supports a variety of digital switchgear solutions
- Suitable for both single and double-busbar applications

Innovative design –setting a new standard for what is possible with a single protection and control device

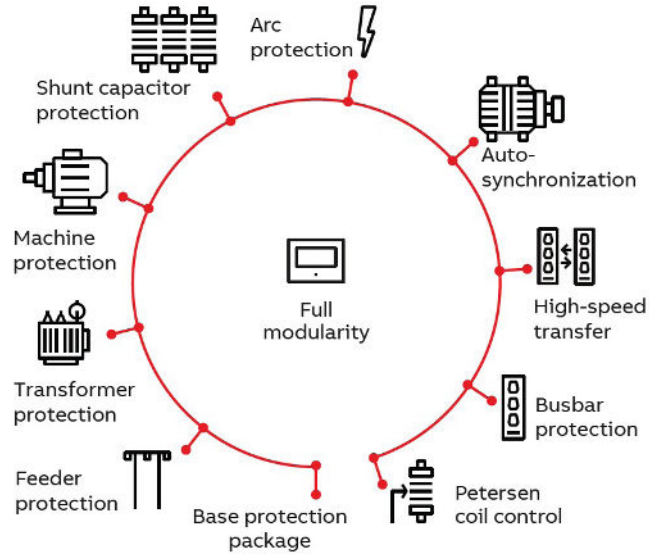

Unmatched flexibility with fully modular hardware and software



Fully modular and scalable hardware and software for maximum flexibility throughout the entire relay life cycle

- Freedom of customization to meet specific protection requirements
- Easy adaptation to changing protection requirements
- Continuous access to the latest software and hardware developments

Unmatched flexibility –helping customers stay ahead of the evolving power network requirements

Long-awaited ease of use with intuitive human-machine interface (HMI)

Increased situational awareness and optimal usability with application-driven local HMI (LHMI)/switchgear HMI (SHMI)

Novel 7-inch color touch screen for visualization of power distribution process information in an entirely new way

Ready-made application-based LHMI pages – saving both time and efforts

Long-awaited ease of use–supporting customers to make sense of complexities in evolving distribution networks

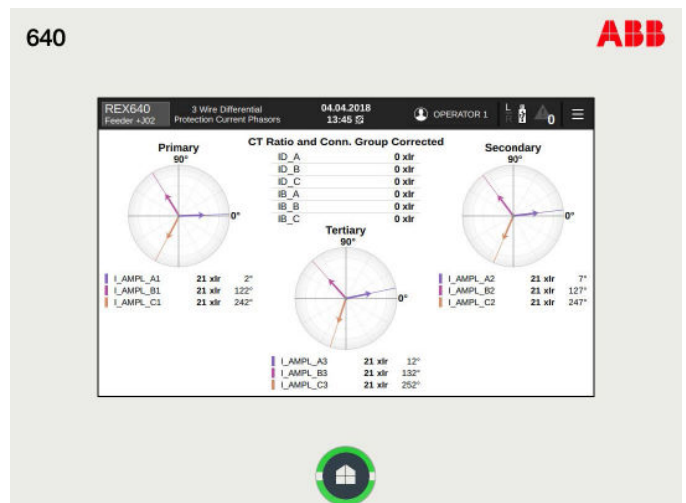



Application and Control

Supported applications

Base Functionality*

- Overcurrent protection
- Earth-fault protection
- Voltage protection
- Frequency protection
- Load-shedding

Feeder / line protection

- Extensive earth-fault protection
- Fault locator
- Line distance protection
- Line differential protection

Power transformer protection and control

- Protection for two and three-winding power transformers
- On-load tap-changer control
- Automatic voltage regulation

High-speed transfer

- Automatic high-speed transfer between main and alternative feeder(s)
- 4 transfer modes: fast, first coincidence, residual voltage-based and time delay-based

Machine protection

- Protection of synchronous and asynchronous machines
- Monitoring of diesel generator sets running in parallel

Generator auto- synchronizer

- Automatic, semi- automatic and manual generator synchronization
- Fully visualized process with LHMI/SHMI

Interconnection Protection

- Protection of interconnection points of distributed generation units

Network auto- synchronizer

- Synchronized closing of non-generator CB by actively adjusting selected generators
- Fully visualized process with LHMI/SHMI

Shunt capacitor protection

- Protection of single Y, double Y and H-bridge- connected capacitor banks
- Protection of harmonic filter circuits

Petersen coil Control

- Automatic control of Petersen coil
- Control of additional fixed parallel coil
- Control of parallel resistor

Busbar protection

- High impedance-based busbar protection

Arc protection

- Four lens or loop-type sensors supported in any combination
- Both sensor types supervised

* Always included

Application packages

The functionality is divided into:

- Comprehensive base functionality – always included
- 17 application packages (optional) – freely selected as required by the intended application (none, some or all)
- 2 additional protection add-ons (for selected application packages) – the add-on packages offer even more functionality on top of the selected application package

Note! The software options can be customized, modified and added at a later stage, even on site after installation.

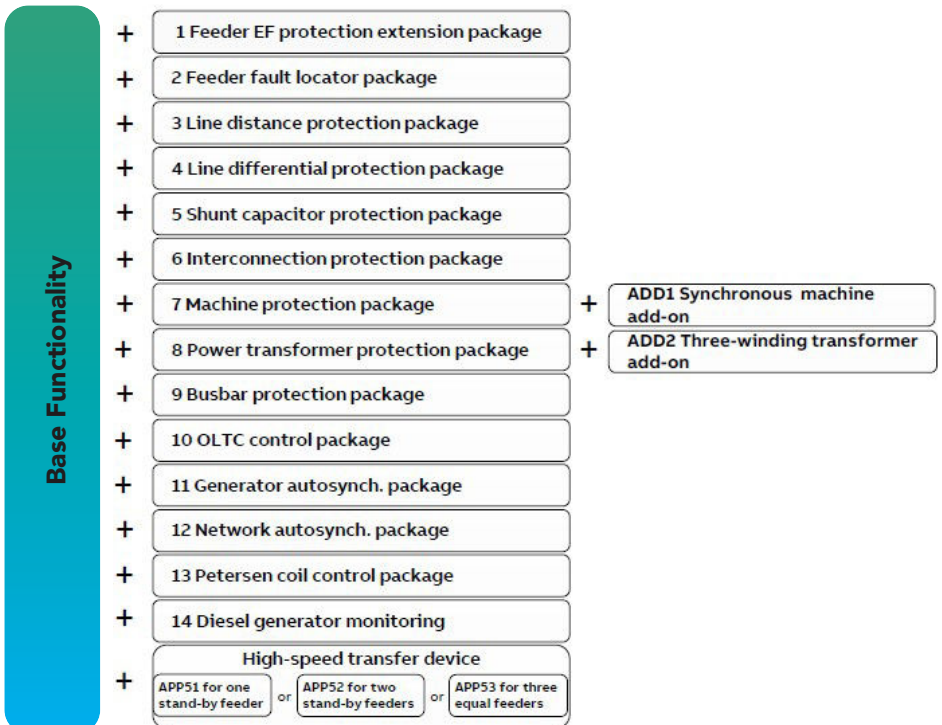



Application package content

Base functionality (always included)

General functions and features

LHMI/SHMI/WHMI

Control and condition monitoring of primary devices

Measurements_3I/3V/In/Vn/f/...

Fault recorder

Disturbance (oscillograph) recorder

IEC61850-9-2LE SMV receiving

IEC61850-8-1 GOOSE

Advanced logics and equations

Alarms, events and audit log

IEC 61850 Ed. 1 and 2.1

IEC 60870-5-103/104, DNP3, Modbus

Time synchronization with IEEE 1588 v2

PRP/HSR redundant communication

Dedicated optical protection communication link

Auto-reclosing (79)

Power quality

Protection functions

Dir. and non-dir. overcurrent protection (50P, 51P, 67P)

Dir. and non-dir. earth-fault protection (50N, 51N, 67G)

Dir. and non-dir. negative-seq. overc. prot. (67Q, 46M)

Phase discontinuity protection (46PD)

Voltage protection (27, 59, 59G, 59N)

Frequency protection (81)

Load-shedding and restoration (1LSH)

Voltage-dependent overcurrent protection (51V)

Thermal protection for lines and cables (49F)

Multipurpose protection (MAP)

Inrush detection (68HB)

Circuit breaker failure protection (50BF)

Restricted earth-fault protection (87N)

Switch onto fault (SOTF)

Load blinder (21LB)

Arc protection (AFD)

Loss of phase, undercurrent protection (37)

Dir. negative-sequence impedance protection (Z2Q)

Feeder earth-fault extension package APP1

Neutral power directional element (67N-TC)

Admittance-based earth-fault prot.(21NY)

Multi-frequency admittance-based. earth-fault protection (67_NYH)

Wattmetric-based earth-fault prot.(32N)

Transient-based earth-fault prot.(67NTEF)

Harmonics-based earth-fault prot.(51NH)

High-impedance earth-fault detection (HIZ)

Touch voltage-based earth-fault protection (46SNQ, 59N)

Feeder fault locator package APP2

Fault locator (FLOC)

Line distance protection package APP3

Distance protection (21P, 21N)

Local acceleration logic (21LAL)

Scheme communication logic (85 21SCHLGC)

Current reversal, weak infeed (85 21CREV, WEI)

Communication logic for residual overcurrent (85 67G/N SCHLGC)

Current reversal, weak infeed for residual overcurrent (85 67G/N CREV, WEI)

Binary signal transfer (BST)

Out-of-step protection (78PS)

Power swing detection (68)

Line differential protection package APP4

Line differential protection (87L)

Binary signal transfer (BST)

Shunt capacitor protection package APP5

Overload protection (51,37,86C)

Current unbalance protection (60N)

3-phase current unbalance protection (60P)

Switching resonance protection (55ITHD)

Neutral unbalance protection (59NU)

Interconnection protection package APP6

Power directional element (67P-TC)

Over voltage variation protection (59.S1)

Low-voltage ride-through protection (27RT)

Voltage vector shift protection (78VS)

Dir. reactive power under volt. prot.(32Q,27)

Dir. overpower protection (32R/32O)

Under power factor protection (55U)

General functions and features

LHMI/SHMI/WHMI

Control and condition monitoring of primary devices

Measurements_3I/3V/In/Vn/f/...

Fault recorder

Disturbance (oscillograph) recorder

IEC61850-9-2LE SMV receiving

IEC61850-8-1 GOOSE

Advanced logics and equations

Alarms, events and audit log

IEC 61850 Ed. 1 and 2.1

IEC 60870-5-103/104, DNP3, Modbus

Time synchronization with IEEE 1588 v2

PRP/HSR redundant communication

Dedicated optical protection communication link

Auto-reclosing (79)

Power quality

Synchronism and energizing check (25)



Application package content

Continued

Base functionality (always included)

Protection functions

Dir. and non-dir. overcurrent protection (50P, 51P, 67P)
Dir. and non-dir. earth-fault protection (50N, 51N, 67G)
Dir. and non-dir. negative-seq. overc. prot. (67Q, 46M)
Phase discontinuity protection (46PD)
Voltage protection (27, 59, 59G, 59N)
Frequency protection (81)
Load-shedding and restoration (1LSH)
Voltage-dependent overcurrent protection (51V)
Thermal protection for lines and cables (49F)
Multipurpose protection (MAP)
Inrush detection (68HB)
Circuit breaker failure protection (50BF)
Restricted earth-fault protection (87N)
Switch onto fault (SOTF)
Load blinder (21LB)
Arc protection (AFD)
Loss of phase, undercurrent protection (37)
Dir. negative-sequence impedance protection (Z2Q)

Machine protection package APP7

Reverse power protection (32R/32O)
Flux-balance based differential prot.(87HIM)
Negative-seq. overcurrent protection (46M)
Loss-of-load supervision (37)
Load jam protection (50TDJAM)
Start-up supervision (49, 66, 48, 50TDLR)
Start-up counter (66)
Phase reversal protection (46R)
Thermal overload protection (49M)
Rotor thermal overload protection (49R)
Stabilized differential protection (87M, 87G)
High-impedance differential protection (87)
Emergency start-up (EST, 62)

Synchronous machine add-on ADD1

Over excitation protection (24)
Thermal overload protection with two time constants (49T/G/C)
Under power protection (32U)
Under impedance protection (21G)
Under excitation protection (40)
Harmonic-based stator earth-fault prot. (64TN)
Injection-based rotor earth-fault prot.(64R)
Out-of-step protection (78PS)
Shaft current leakage protection (38, 51)
Under power factor protection (55U)
Accidental energization protection (27, 50)

Power transformer protection package APP8

Over excitation protection (24)
Thermal overload protection with two time constants (49T/G/C)
Directional overpower protection (32R/32O)
Under power protection (32U)
Under impedance protection (21G)
Stabilized differential protection for 2-winding transformers (87T)
High-impedance differential protection (87)
Hotspot and aging monitoring (26/49HS)
Tap-changer position indication (84T)

General functions and features

LHMI/SHMI/WHMI
Control and condition monitoring of primary devices
Measurements_3I/3V/In/Vn/f/...
Fault recorder
Disturbance (oscillograph) recorder
IEC61850-9-2LE SMV receiving
IEC61850-8-1 GOOSE
Advanced logics and equations
Alarms, events and audit log
IEC 61850 Ed. 1 and 2.1
IEC 60870-5-103/104, DNP3, Modbus
Time synchronization with IEEE 1588 v2
PRP/HSR redundant communication
Dedicated optical protection communication link
Auto-reclosing (79)
Power quality
Synchronism and energizing check (25)

Protection functions

Dir. and non-dir. overcurrent protection (50P, 51P, 67P)
Dir. and non-dir. earth-fault protection (50N, 51N, 67G)
Dir. and non-dir. negative-seq. overc. prot. (67Q, 46M)
Phase discontinuity protection (46PD)
Voltage protection (27, 59, 59G, 59N)
Frequency protection (81)
Load-shedding and restoration (1LSH)
Voltage-dependent overcurrent protection (51V)
Thermal protection for lines and cables (49F)
Multipurpose protection (MAP)
Inrush detection (68HB)
Circuit breaker failure protection (50BF)
Restricted earth-fault protection (87N)
Switch onto fault (SOTF)
Load blinder (21LB)
Arc protection (AFD)
Loss of phase, undercurrent protection (37)
Dir. negative-sequence impedance protection (Z2Q)

Three-winding transformer add-on ADD2

Stabilized differential protection for 3-winding transformers (87T3)
Busbar protection package APP9
High-impedance differential protection (87)
Current transformer supervision (CCM)

Tap-changer control package APP10

Power directional element (67P-TC)
Voltage regulator (90V)
Tap-changer position indication (84T)
Generator auto synchronizer package APP11
Auto synchronizer for generator circuit breaker (25AUTOSYNCG)

Network auto synchronizer package APP12

Auto synchronizer for network circuit breaker (25AUTOSYNGBT/T)
Petersen coil control package APP13
Petersen coil controller (90)
Diesel generator monitoring package APP14
Diesel generator monitoring (32/40G)

High-speed transfer device package APP51

High-speed bus transfer for one stand-by feeder (I<-->O BT)
High-speed transfer device package APP52
High-speed bus transfer for two stand-by feeders (I<-->O BT)
High-speed transfer device package APP53
High-speed bus transfer for three equal feeders (I<-->O BT)

Protection and control REX640

HMI options

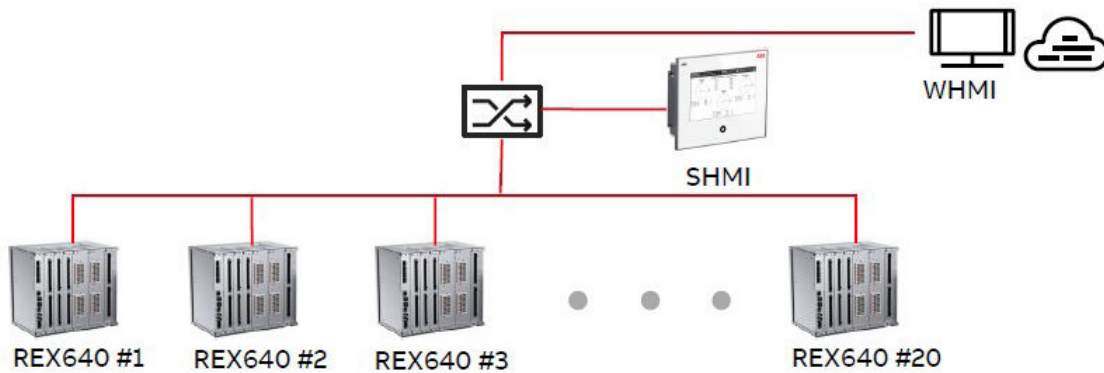
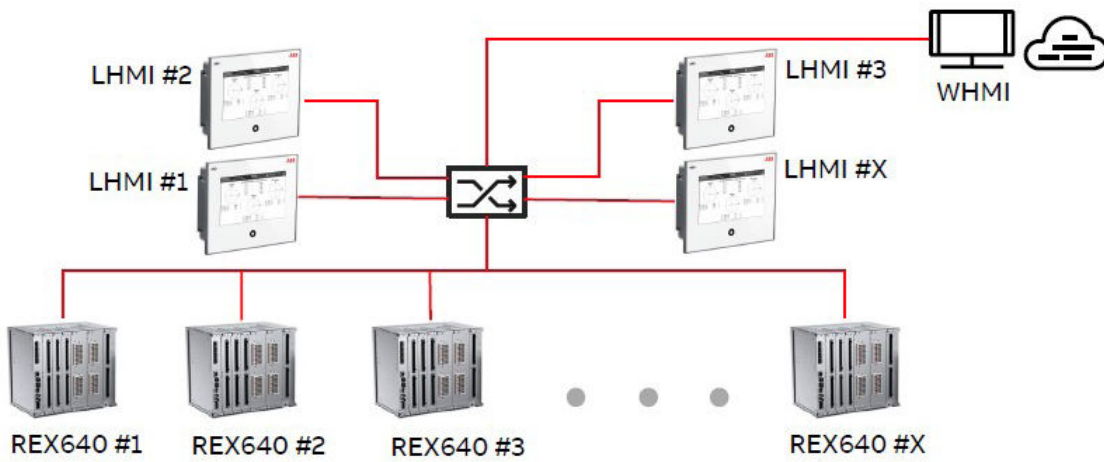
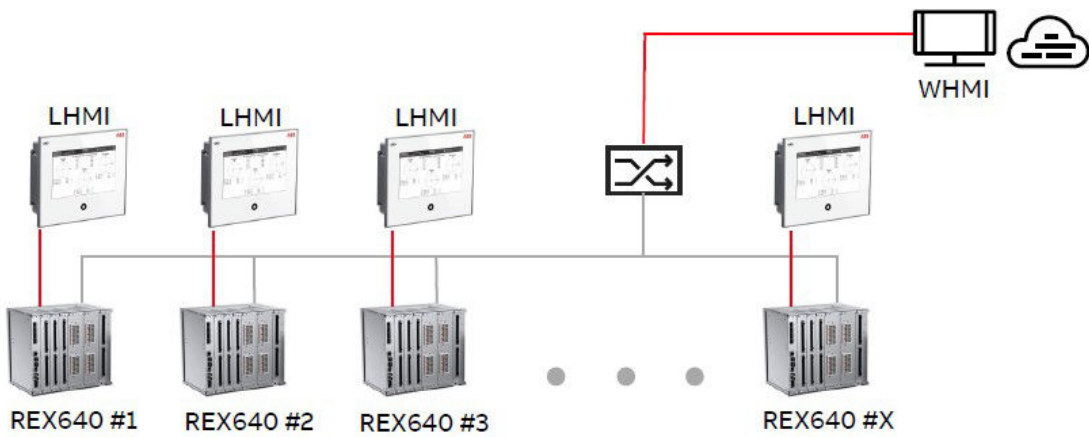
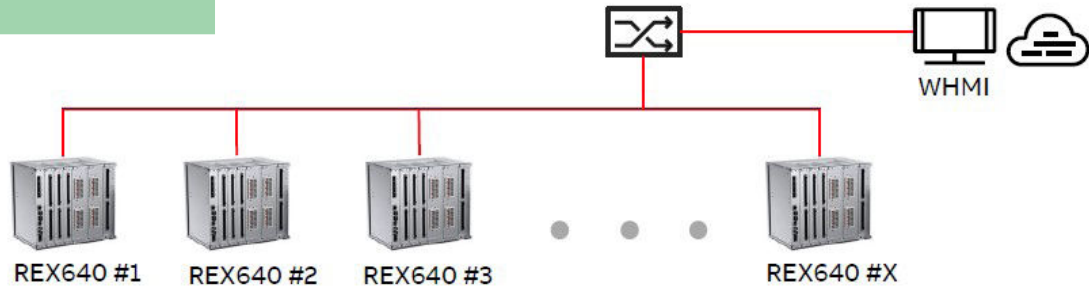

Protection and control REX640

Switchgear HMI (SHMI)

Switchgear level

Switchgear primary object position statuses
Alarm status indications
Internal status indications
Backups of relay configurations and settings



SHMI



Single panel/bay level



SHMI



Bay primary object control
Bay primary object position status
Measurements
Alarm indication
Alarm listing
Relay status indication
Event listing
Fault records
Disturbance records
Settings
Commissioning and testing support
Backup of relay configuration and settings

REX640 / Summary

Innovative, flexible and easy to use

- The outcome of a long-standing evolution – building on ABB's strong heritage of freely configurable multi-functional relays
- Complete application coverage with one device for optimal flexibility and cost-effectiveness
- Designed to support the increasing digitalization of substations
- Fully modular and scalable hardware and software for maximum flexibility throughout the entire relay life cycle – from customizing your relay to adapting to changing protection requirements
- Continuous access to the latest software and hardware developments
- Increased situational awareness and optimal usability with application-driven LHMI/SHMI
- Member of ABB's Relion® protection and control family of relays – reinforcing Relion's position as the family of relays to rely on



Protection and control REX640

All-in-one protection for any power distribution application

REX640 makes protecting all your assets in advanced power generation and distribution applications easy. The fully modular design allows unequaled customization and modification flexibility, and easy adaptation to changing protection requirements throughout the relay life cycle. This is asset management at its best.

Complete application coverage with one device for optimal cost-effectiveness

REX640 is the outcome of a long-standing evolution, building on ABB's strong heritage of freely configurable multi-functional relays. The ability to cover the full range of utility and industrial applications and manage multiple applications simultaneously, with the same device, guarantees flexible, versatile and cost-efficient protection solutions.

REX640 has been designed to support the increasing digitalization of substations. REX640 thereby supports a variety of digital switchgear solutions and is suitable for both single and double-busbar applications. REX640 offers as many as 20 current and voltage measurement channels in total, supporting both conventional instrument transformers and sensors, not to mention the ability to receive four streams of sampled measured values (SMV) via IEC 61850-9-2 LE-based process bus communication.

REX640 is a member of ABB's Relion® protection and control family of relays, reinforcing Relion's position as the family of relays to rely on.

Application package concept for maximum convenience and flexibility

REX640 offers a variety of ready-made application packages to choose from. The application packages include various protection and control functions, which can be flexibly combined to create protection solutions that meet your unique protection requirements. The available packages support the following applications:

- Feeder protection
 - Line differential protection
 - Line distance protection



- Interconnection protection
- Fault locator
- Power transformer protection
 - Two and three-winding differential protection
 - On-load tap-changer control
- Machine protection
 - Asynchronous machines
 - Synchronous machines
 - Diesel generator sets running in parallel
- Shunt capacitor protection
- Busbar protection
- Automatic high-speed transfer
- Automatic synchronization
 - Generator circuit breaker
 - Non-generator circuit breaker
- Petersen coil control
- Arc protection with supervised sensors
 - Loop and lens-type sensors

Fully modular hardware and software for maximum flexibility for the entire relay lifetime

The modularity and scalability of both software and hardware allow you to create your own, unique relay for your specific protection requirements. The ready-made application packages make ordering your

relay smooth and easy.

When requirements change, so will REX640. Adapting to changing protection requirements is flexible and easy – the software and hardware can be modified anytime. In addition, new software and hardware developments will be continuously and easily accessible – throughout the relay's entire life cycle.

Intuitive human-machine interface for increased situational awareness

REX640 offers three human-machine interface (HMI) options, a Web HMI (WHMI), an intuitive panel/bay-level local HMI (LHMI) and a cost-efficient switchgear HMI (SHMI), of which the WHMI is always included. The ability to cover up to 20 REX640 relays with one SHMI provides optimal switchgear visibility. In addition, complete LHMI functionality on panel/bay level is available by selecting one panel/bay at a time.

The LHMI can be connected either to the relay or station communication network, whereas the SHMI is always connected to the station communication network. This allows installation away from the



switchgear, which increases operator safety.

Secure and flexible standardized communication

REX640 supports a variety of communication protocols for access to operational information and controls, such as IEC 61850 Edition 1 and Edition 2.1,

IEC 60870-5-103, IEC 60870-5-104, Modbus®, DNP3, and Profibus DVP1 with the protocol adapter SPA-ZC 302. Full support for the IEC 61850 standard covers the parallel redundancy protocol (PRP) and high-availability seamless redundancy (HSR) protocol, fast GOOSE (Generic Object-Oriented Substation Event) messaging, and the IEC 61850-9-2 LE process bus for less wiring and supervised communication, to

mention a few. For optimal cyber security, REX640 supports secure communication for the IEC 60870-5-104 and DNP3 protocols according to the IEC 62351 standard.

To facilitate the mapping of the relay's IEC 61850 data model to that of the customer, REX640 supports flexible product naming (FPN). FPN allows customers to use a standardized data model in their SCADA (Supervisory Control And Data Acquisition) system, irrespective of the relay vendor and the vendor-specific data model.

REX640 – innovative, flexible and easy to use

- Complete application coverage with one device for optimal flexibility and cost-effectiveness
- Ready-made application packages for

convenient and smooth ordering

- Customization freedom with modular and scalable design
- Fully modular hardware and software for maximum flexibility and easy adaption to changing protection requirements
- Continuous access to the latest software and hardware developments
- Increased situational awareness and optimal usability with application-driven LHMI/SHMI
- Relay costs reduced by up to 15% with SHMI instead of LHMI
- Designed to support the increasing digitalization of substations



Spike Electric Controls
5914 E. Sam Houston Pkwy S.
Houston TX 77034

Toll Free 1.844.279.8295 • Local Factory Support 832.243.5372 • Fax 832.569.5645
sales@spikeelectric.com spikeelectric.com

Copyright © 2024 Spike Electric Controls

We reserve the right to make technical changes or modify the contents of this document without prior notice. With regard to purchase orders, the agreed particulars shall prevail. Spike Electric Controls does not accept any responsibility whatsoever for

potential errors or possible lack of information in this document.

We reserve all rights in this document and in the subject matter and illustrations contained therein.

Any reproduction, disclosure to third parties or utilization of its contents – in whole or in parts – is forbidden without prior written consent of Spike Electric Controls.
All rights reserved.