

SAFE SYNC

Medium 5kV & 15kV Voltage Power Transfer Switches

Spike Electric Controls presents innovative solutions that safeguard power integrity - from the conceptual stage right through to deployment, initiation, and sustained usage: all-encompassing protection for uninterrupted energy.

Sales Flyer



Microprocessor-Driven Control Center:

At the heart of the Safe Sync SERIES is our state-of-the-art microprocessor-driven Control Center, expertly designed to manage breaker operations, seamlessly transitioning critical loads between power sources.

Encompassing two voltage classifications - 15 kV and 5 kV - our Medium Voltage Transfer Switch can be tailored with a variety of accessories and unique specifications to fulfill distinct installation needs.

Switch mode variants available are:

- Open transition
- Delayed transition
- Closed transition

Our assemblies boast a robust metal-clad design, distinct control barriers, easily removable circuit breakers, and high-quality voltage transformers, ensuring optimal performance across the stipulated amperage and voltage ranges.

**SAFE SYNC SERIES MEDIUM
5kV & 15kV VOLTAGE POWER
TRANSFER SWITCHES**

About Safe Sync:

In an electrified world, the steadiness, caliber, and dependability of energy not only influence everyday life but are paramount for safety, operational excellence, and fiscal prosperity.

Spike Electric Controls presents innovative solutions that safeguard power integrity - from the conceptual stage right through to deployment, initiation, and sustained usage: all-encompassing protection for uninterrupted energy.

Our Safe Sync series has been meticulously crafted to turn potential energy disruptions into unwavering confidence.

Offering a diverse range of configurations, supplementary features, and transfer mechanisms such as prompt, deferred, sealed, and gentle load transitions, the Spike Electric Safe Sync SERIES assures performance that meets and even exceeds industry standards and is UL 1008A compliant.



Applications:

- Data Management Hubs
- Medical Institutions
- Telecommunication Hubs
- Industrial Estates
- Petrochemical Plants
- Production Facilities
- Continuous Operations
- Consumer Business Centers
- Research Laboratories
- Educational Campuses
- Municipal Utilities



Certifications:

We pride ourselves on meeting and surpassing the following industry benchmarks:

- ANSI/IEEE C37.20.2 – Standard for Metal-Clad Switchgear
- ANSI/NEMA C37.55 – Medium Voltage Metal-Clad Assemblies – Testing & Conformance Procedures

Below is a synopsis of the diverse voltage, current, and interrupt class ratings on offer:

Spike Electric Safe Sync SERIES 1200 Amp Medium Voltage Power Transfer Switch

Voltage Classes	Interrupt Classes (kA Symm.)	Rated Current (A)	Construction Details
15 kV	25, 40 kA, 50 kA	1200 Amps	Metal-Clad Switchgear adhering to ANSI C37.20.2, UL 1008A listed, featuring draw-out vacuum circuit breakers and high-caliber transformers
5 kV	40 kA, 50 kA	1200 Amps	Metal-Clad Switchgear adhering to ANSI C37.20.2, UL 1008A listed, featuring draw-out vacuum circuit breakers and high-caliber transformers

The Spike Electric Safe Sync SERIES embodies paramount defense, unwavering reliability, and secure maintenance. Our strict adherence to industry standards ensures:

- UL Compliance
- ANSI/IEEE C37.20.2 Benchmark for Metal-Clad Switchgear

Rated for optimal performance at either 5 kV or 15 kV, the Medium Voltage Power Transfer Switch boasts a range from 1200 up to 3000 amperes. As for the interrupt capacity, users can select from the 25, 40, or 50 kA symmetrical class options.

Our base medium voltage transfer switch structure is segmented into two to three vertical sections based on the current rating. Supplementary features, such as expansive metering or relaying, could necessitate additional sections. The fundamental configuration for a 1200 ampere switch integrates a minimum of two sections, while the 2000 or 3000 ampere versions encompass at least three sections. The combined sections cater to specific needs - be it seismic certifications, fortified outdoor casings, or other unique prerequisites, tailoring each assembly to the client's exact specifications.

Construction:

Prominent components and attributes encompass:

- Safe Sync Series Advanced Control Center
- Slide-Out, Shuttered Vacuum Circuit Breakers with Optional Protection Systems:
- A Standard Source VCB for the Transfer Switch
- A Backup Source VCB for the Transfer Switch
- Dual Standard Source Fused Slide-Out Voltage Transformers (Configured in WYE-WYE)
- Dual Backup Source Fused Slide-Out Voltage Transformers (Configured in WYE-WYE)



Codes & Regulations:

- UL 1008A Accredited – Benchmark for Medium Voltage Transfer Switches
- National Electrical Guidelines (ANSI/NFPA 70)
- Article 517 – Medical Care Establishments
- Article 700 – Urgent Power Systems
- Article 701 – Mandated Backup Systems
- Article 702 – Elective Backup Systems
- Article 708 – Vital Operations Power Frameworks

A seamlessly unified multi-section metal-clad framework





Certification Highlights:

Earthquake Resistance - readily obtainable upon initiation of order

Arc Safety Provisions:

Features aimed at arc safety can encompass arc-protective design and specialized arc detection mechanisms.

Switch Control Unit:

Our Safe Sync Control Center, which epitomizes excellence in directing both low and medium voltage switches, draws upon decades of groundbreaking power transfer insights and expertise.

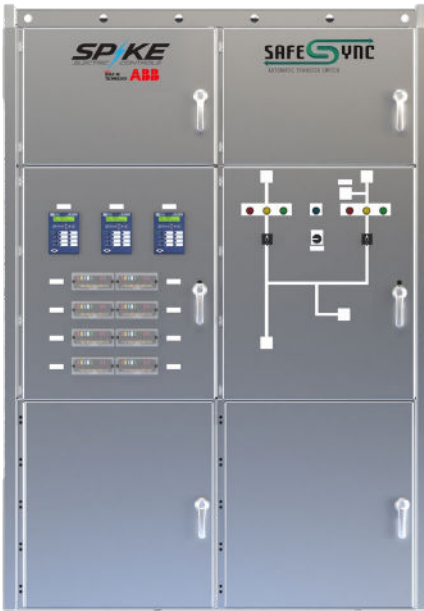

Circuit Breaker Dynamics:

These circuit breakers overshadow contactors in terms of reliability and ease of upkeep. Each breaker houses three distinct vacuum interrupters equipped with an embedded contact wear gap monitor. Built-in stored energy components ensure swift fault isolation and interruption. Their design promises secure inspections and straightforward maintenance. Both Standard Source and Backup Source breakers are swappable, maintaining uniform ratings and layout. Energy storage facets cover both electric motor recharging and a manual charging lever.

Instrumentation Transformers:

This includes Current Transformers (CT) and Voltage Transformers (VT, also known as Potential Transformers - PT) that measure electrical flow and voltage.

The conventional design features ANSI relay class transformers crafted as per ANSI C57.13 to guarantee uniform and dependable operations. Further enhancements like grounded carriage-mounts ensure secure maintenance, along with fuses for circuit safety.

Customized requirements, be it revenue-grade instruments, testing blocks, or added safety relays, can be integrated seamlessly.

Core Model Specifications & Design

Features:

Feature	5 kV / 15 kV (1200 A)	5 kV / 15 kV (2000 A / 3000 A)
Sections (Minimum Count)	2	3
Standard NEMA 1 Sizing	36"Wx92"Dx95"H	36"Wx92"Dx95"H
UL 1008A Compliance	Yes	Yes
ANSI C37.20.2	Yes	Yes
Seismic Certification	On Demand	Yes
Insulated Bus	Yes	Yes
Cable Blockers	Yes	Yes
11 Gauge Steel (Exterior Panels)	Yes	Yes
Slide-Out Breakers	Yes	Yes
Auto Shutters	Yes	Yes
Earthed Dividers	Yes	Yes
Electrostatic Powder Coating	Yes	Yes
Distribution Potential	Yes	Yes
Safety Relays Option	Yes	Yes
NEMA 3R Non-Walk-In Variant	Yes	Yes

Transition Options & Control Modes

Open Transition Transfer Switching:

Safe Sync allows for "non-synchronized" transfer if the preferred source is deemed "unstable" and the alternate source requires time come on-line. Additionally, if conditions require upstream/downstream protective actions to process before aligning loads to the alternate source.

Delayed Transition Transfer Switching:

Safe Sync allows for "non-synchronized" transfer if conditions require controlled transfer of energized loads that can withstand a short loss and return of power such as non-rotational loads, VFD, auto-restart load centers.

Closed Transition Transfer Switching:

Safe Sync allows for "synchronized" transfer if the conditions allow for safe, momentary parallel operations of available sources. Available communication protocols provide seamless integration with generator control systems to allow non-interrupted service for controlled switching evolutions.





User Control Modes:

Automatic & Manual: The mode selector switch empowers users to toggle between automated and manual control effortlessly. The options range from open, delayed, to closed transitions, inclusive of the soft load control. For enhanced safety, electrically safeguarded manual controls are embedded on the front panel for supervised operations.

Breaker Control & Mode Selector Switches:

- Enables users to manually trip or close the breaker, irrespective of the mode.
- Features indicators for easy understanding: Red for Closed, Green for Open, and Amber for Tripped.
- The embedded electrical interlocks ensure that there's no chance of simultaneous activation, guaranteeing utmost safety.

Controller & Protection Relay:

The Safe Sync MV Transfer Switch, equipped with the SEL 700GT+ Relays, serves dual functions as both a controller and a protection relay. This integrated approach not only minimizes potential failure points but also simplifies inventory management. By reducing the need to stock various types of control components, it ensures more efficient and cost-effective maintenance, especially in scenarios where a controller or relay replacement is required.



Green Energy Efficient:

As the world pivots towards renewable energy, the MVTS of the future must effortlessly integrate with sources like solar and wind. Spike Electric Controls is leading the charge, innovating MVTS solutions that bridge conventional and renewable power seamlessly.

The Impetus for Green Integration

- **Harnessing Renewables:** The future MVTS will seamlessly integrate with renewable energy sources, acting as bridges between conventional and green power.
- **Smart Grids and MVTS:** By aligning with evolving smart grid technologies, future MVTS, especially those of Spike Electric's caliber, will become even more central to sustainable power management.





AMVAC™ 5/15/27 kV ANSI Magnetic Mechanism Vacuum Circuit Breaker

General Overview:

The AMVAC breaker is a magnetically actuated and latched breaker capable of a high number of operations due to its simplified design. Fully compliant with IEEE Standards C37.04, C37.06 and C37.09, the AMVAC breaker is a great fit for many applications.



Features:

- Mechanical operations counter
- Optional roll-on-floor design
- Open, closed, ready/not ready lights and pushbuttons
- Maintenance-free magnetic actuator

Available AMVAC breaker ratings

Voltage class	Nominal voltages	Continuous current	Short circuit/with-stand (2 sec)	Close and latch	BIL (lightning impulse withstand)	Low frequency withstand (Hi-Pot)
kV	kV	A	kA, rms	kA, peak	kV, crest	kV, rms
5	2.4, 4.16, 4.8	1200, 2000, 3000	25	65	60	19
			31.5	82		
			40	104		
			50	130		
8.25	4.8, 6.9, 7.2	1200, 2000, 3000	40	104	95	36
			25	65		
			31.5	82		
			40	104		
15	6.9, 7.2, 8.4, 11, 12, 12.47, 13.2, 13.8, 14.4	1200, 2000, 3000	50	130	95	36
			16	42		
			25	65		
			27	125		

Construction:

Magnetic Actuator:

Introduced in 1997, the bi-stable magnetic actuator is used in many ABB products, including the AMVAC breaker. Due to its simple design, no maintenance on the actuator is necessary for the lifetime of the product.

The magnetic actuator operates on the principle of shifting magnetic flux and is latched into one of the stable positions by rare-earth magnets which require no power.



Magnetic actuator

Vacuum Interrupters:

ABB vacuum interrupters (VIs) are embedded in a solid insulation material to protect the VIs from collecting dust or moisture and from accidental bumps. The solid insulation also improves tracking resistance making ABB circuit breakers some of the lightest available in the market. Because of the embedded design, these vacuum interrupters are maintenance-free for the life of the VI.



Vacuum interrupters

On-board Capacitors:

The on-board capacitors of the AMVAC breaker deliver the current needed for creation of magnetic fields within the mechanism thereby eliminating current draw and voltage drop from the battery bank for the substation.

For more information on the maintenance of the capacitors, please see the AMVAC Installation, Operation and Maintenance Manual.



On-board capacitors



AMVAC™ 5/15/27 kV ANSI Magnetic Mechanism Vacuum Circuit Breaker

Electronic Control Board:

The electronic control board technology for the AMVAC breaker provides improved reliability due to its self-monitoring functions and features. Featuring coil monitoring, sensor monitoring, optional under-voltage trip and optional energy failure trip, the AMVAC breaker is customizable for any application.

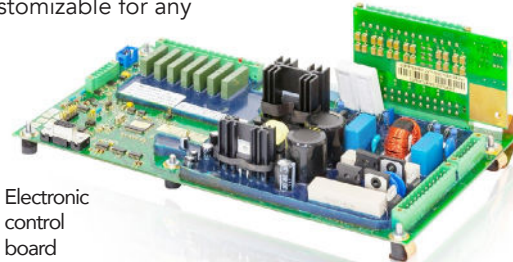

Electronic control board

By managing the 45 ms current limited pulse delivered to the mechanism by the on-board capacitors, the electronic control board eliminates one cause of common failures in typical spring mechanism breakers – the burning of trip and close coils.

Breaker Racking Truck:

ABB's breaker racking truck for switchgear is integral to the breaker itself in lieu of being inside the switchgear breaker cell. Rated for 180 foot-pounds of torque, the breaker racking truck exceeds the industry standard of 50-60 foot-pounds by a factor of three, greatly reducing the possibility of an over-torque condition.



Breaker lift truck

The breaker racking truck is rated for 1000 rack in-rack out operations, exceeding the ANSI Standard of 500 operations.

Capacitor Bank Switch Ratings

Voltage class	Continuous current	Short circuit current	Capacitor switching ratings			
kV	A	kA	Type	Notes		
5	1200	25	C0	25 A cable charging		
		31.5	C0	25 A cable charging		
		40	C0	25 A cable charging		
		50	C0	630 A back to back capacitor bank		
		2000	25	C0	25 A cable charging	
			31.5	C0	25 A cable charging	
	40		C0	630 A back to back capacitor bank		
	50		C0	630 A back to back capacitor bank		
	3000		25	C1	630 A back to back capacitor bank	
			31.5	C1	630 A back to back capacitor bank	
		40	C1	630 A back to back capacitor bank		
		50	C1	630 A back to back capacitor bank		
8.25		1200	40	C1	630 A back to back capacitor bank	
		2000	40	C1	630 A back to back capacitor bank	
	3000	40	C1	630 A back to back capacitor bank		
15	1200	25	C0	25 A cable charging		
		31.5		25 A cable charging		
		40	C1	630 A back to back capacitor bank		
		50	C1	1000 A back to back capacitor bank		
		2000	25		25 A cable charging	
			31.5		25 A cable charging	
	40		C1	630 A back to back capacitor bank		
	50		C1	1000 A back to back capacitor bank		
	3000		25	C1	630 A back to back capacitor bank	
			31.5	C1	630 A back to back capacitor bank	
		40	C1	630 A back to back capacitor bank		
		50	C1	1000 A back to back capacitor bank		
		27	1200	16	BTB	400 A back to back capacitor bank
				25	BTB	400 A back to back capacitor bank
	2000			16	BTB	400 A back to back capacitor bank
			25	BTB	400 A back to back capacitor bank	



AMVAC™ 5/15/27 kV ANSI Magnetic Mechanism Vacuum Circuit Breaker

Timing Characteristics:

Total interrupting time consists of opening time plus the time required for arc interruption. Total interrupt time is 50 ms or less for three cycle breakers and 83 ms or less for five cycle breakers.

Voltage class	Continuous current	Short circuit current	Interrupt time	Closing time
kV	A	kA	Cycles	ms
5	1200	25	3	45-60
		31.5	3	45-60
		40	5	45-60
		50	5	45-60
	2000	25	3	45-60
		31.5	3	45-60
		40	3	45-60
		50	5	45-60
	3000	25	3	45-60
		31.5	3	45-60
		40	3	45-60
		50	5	45-60
8.25	1200	40	3	45-60
	2000	40	3	45-60
	3000	40	3	45-60
15	1200	25	3	45-60
		31.5	3	45-60
		40	3	45-60
		50	3	45-60
	2000	25	3	45-60
		31.5	3	45-60
		40	3	45-60
		50	3	45-60
	3000	25	3	45-60
		31.5	3	45-60
		40	3	45-60
		50	3	45-60
27	1200	16	3	45-60
		25	3	45-60
	2000	16	3	45-60
		25	3	45-60





AMVAC™ 5/15/27 kV ANSI Magnetic Mechanism Vacuum Circuit Breaker

Mechanical Endurance Ratings:

Voltage class	Continuous current	Short circuit current	No load mechanical operations
kV	A	kA	
5	1200	25	10000
		31.5	10000
		40	10000
		50	10000
	2000	25	10000
		31.5	10000
		40	10000
		50	10000
	3000	25	10000
		31.5	10000
		40	10000
		50	10000
8.25	1200	40	10000
	2000	40	10000
	3000	40	10000
15	1200	25	10000
		31.5	10000
		40	10000
		50	10000
	2000	25	10000
		31.5	10000
		40	10000
		50	10000
	3000	25	10000
		31.5	10000
		40	10000
		50	10000
27	1200	16	10000
		25	10000
		16	10000
	2000	16	10000
		16	10000
		16	10000

Power Requirements and Auxiliary Switch Ratings

Power requirements

	Actuator driver
Standby	10 W
Capacitor charging	100 W
Trip/close	0.25 W

Auxilliary contacts	Nominal control power voltage					
	24 Vdc	48 Vdc	125 Vdc	250 Vdc	120 Vac	240 Vac
Rated carrying current	10 A	10 A	10 A	10 A	10 A	10 A
Rated breaking current	10 A	7.6 A	4.4 A	1.8 A	2.6 A	2.3 A
Maximum breaking current	12 A	10 A	6 A	0 A	26 A	23 A



AMVAC™ 5/15/27 kV ANSI Magnetic Mechanism Vacuum Circuit Breaker

Dimensions and Weight:

Voltage class	Continuous current	Short circuit current	Height	Width	Depth	Weight
kV	A	kA	in	in	in	lb
5	1200	25	28	31	27	334
		31.5	28	31	27	334
		40	28	31	27	410
		50	28	31	27	410
	2000	25	28	31	27	419
		31.5	28	31	27	419
		40	28	31	27	419
		50	28	31	27	419
	3000	25	28	31	27	459
		31.5	28	31	27	459
		40	28	31	27	459
		50	28	31	27	459
8.25	1200	40	28	31	27	410
	2000	40	28	31	27	419
	3000	40	28	31	27	459
15	1200	25	28	31	27	334
		31.5	28	31	27	334
		40	28	31	27	410
		50	28	31	27	430
	2000	25	28	31	27	419
		31.5	28	31	27	419
		40	28	31	27	419
		50	28	31	27	430
	3000	25	28	31	27	459
		31.5	28	31	27	459
		40	28	31	27	459
		50	28	31	27	481
27	1200	16	30	31	27	410
		25	30	31	27	410
	2000	16	30	31	27	419
			30	31	27	419





AMVAC™ 5/15/27 kV ANSI Magnetic Mechanism Vacuum Circuit Breaker

Internal Diagram:

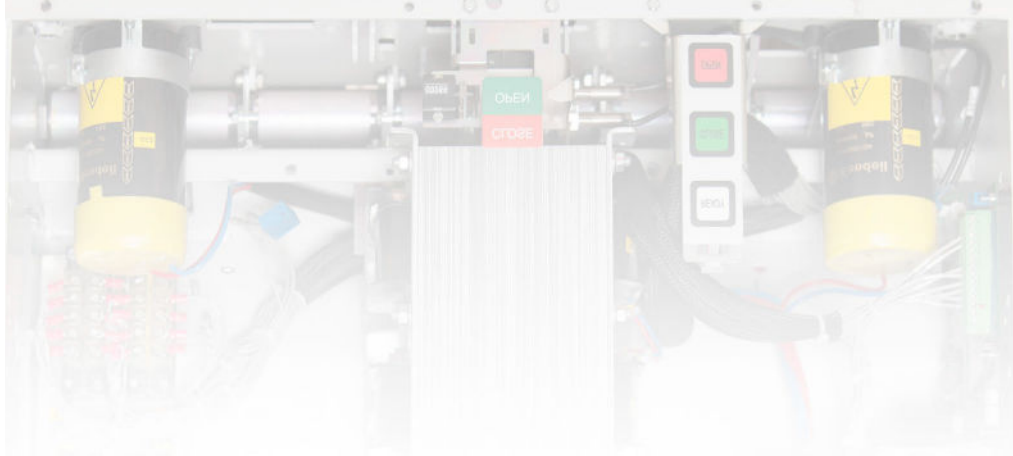
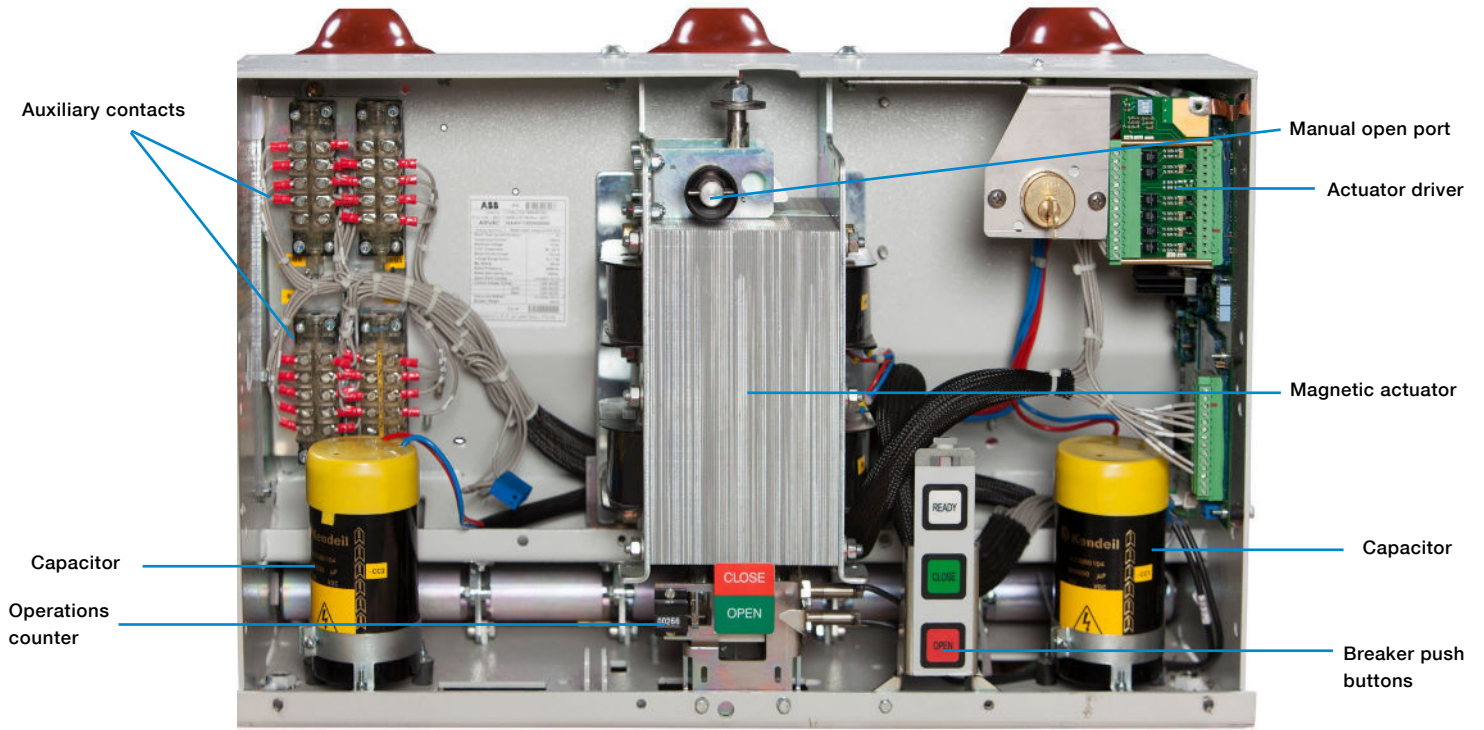



AMVAC™ 5/15/27 kV ANSI Magnetic Mechanism Vacuum Circuit Breaker

Outline Drawing:

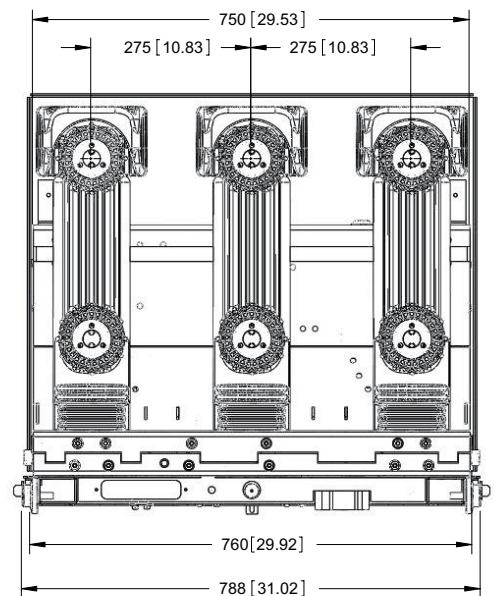
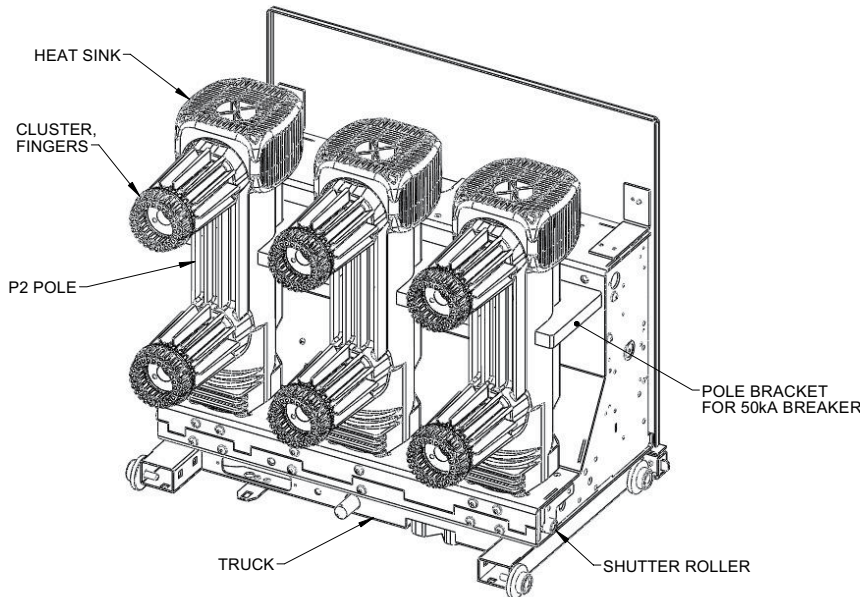
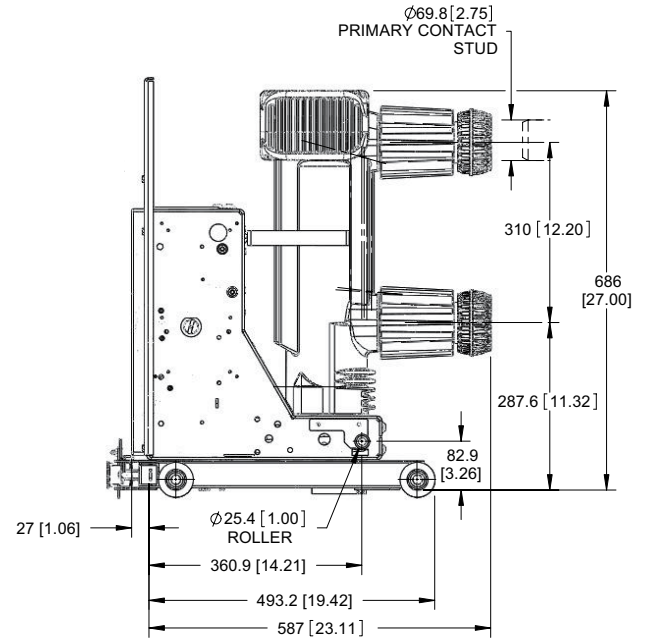
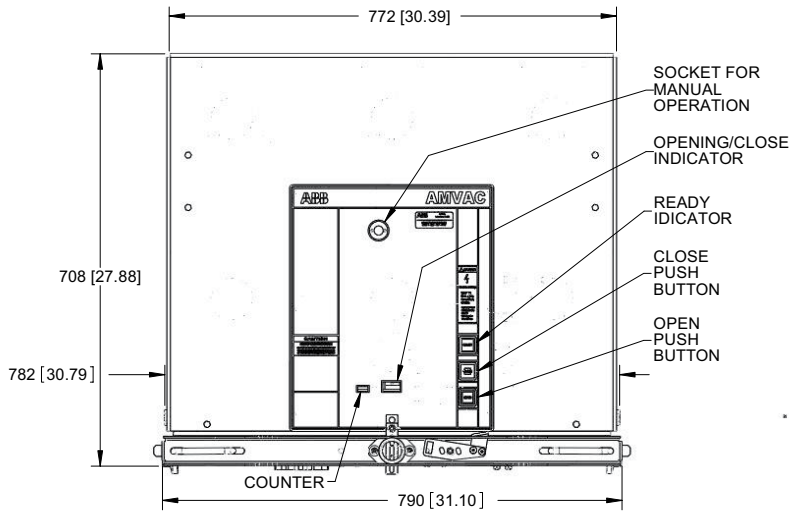



AMVAC™ 5/15/27 kV ANSI Magnetic Mechanism Vacuum Circuit Breaker

Schematic Drawing:

AMVAC circuit breakers are supplied with dual secondary disconnects, which includes 9 normally open "a" contacts and 8 normally closed "b" contacts.

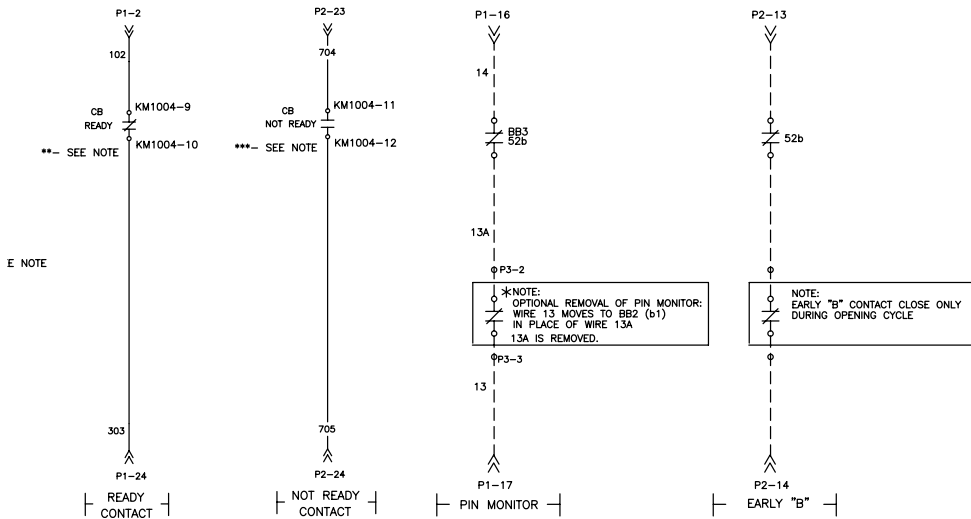
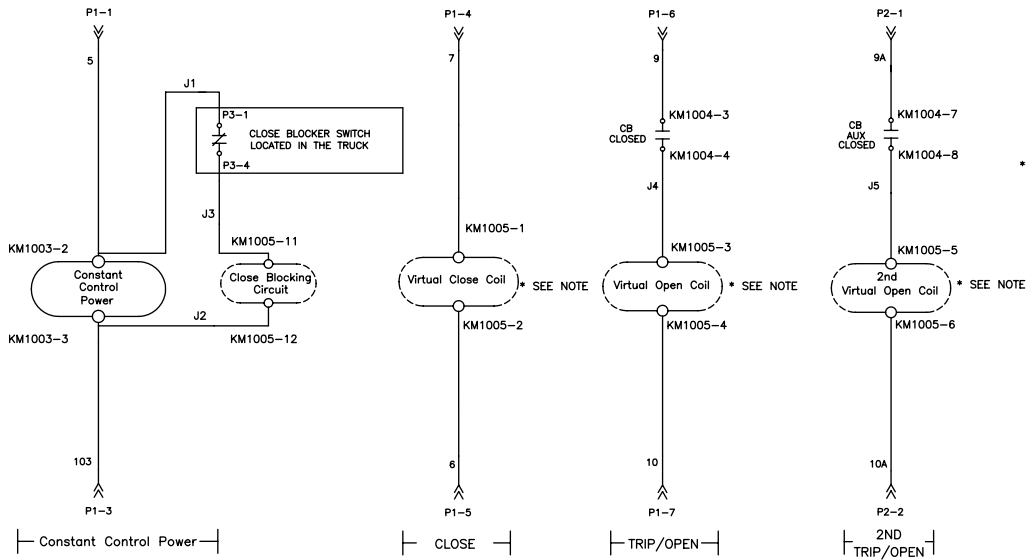



AMVAC™ magnetically actuated circuit breaker

Five year warranty

A five year comprehensive warranty is available on the complete breaker and breaker truck assembly, with 24 hours / 7 days-a-week customer service.

The AMVAC™ breaker is truly the next generation in medium voltage vacuum circuit breaker technology. ABB is the first to combine the unique benefits of embedded vacuum interrupter technology with a magnetic actuator designed to reduce operating costs and increase reliability.

Using a flux-shifting device with integral permanent magnets, the AMVAC mechanism has only one moving part. With simple open and close coils, an electronic controller and capacitors for energy storage, the AMVAC circuit breaker meets or exceeds ANSI mechanical and load operation requirements.

Low maintenance = reduced operating costs

- No maintenance required on the magnetic actuator
- Closing and tripping is a current limited pulse – eliminates failed trip coils



Significantly less moving parts = reliability and safety

- Simple magnetic actuator with one moving part
- Elimination of close and trip coils, motors, cams, and linkages and the associated spare parts inventory
- Increased safety by eliminating maintenance on mechanically charged components, coils, and motors

Durable design = longer life

- High dielectric strength with embedded vacuum interrupters in solid material insulation

ABB stands ready to work with you to supplement this product offering with technical application experts, spare parts, training and support services intended to reduce your total cost of ownership.



SEL-700GT Intertie Protection Relay



Field-configurable front panel, including display, LEDs, and pushbuttons.

Ethernet, serial, and expanded I/O options.

Field-upgradable design.

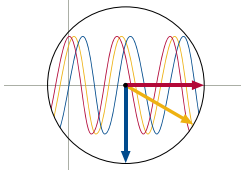

SEL Synchphasors®

Complete Intertie and Generator Protection



Distributed Generation Intertie

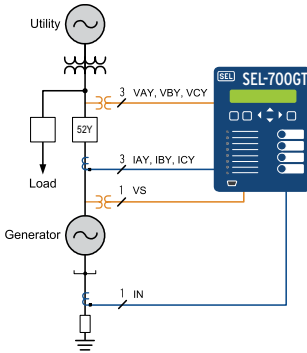

Provides IEEE 1547-compliant protection.

Protects electric grid and distributed generation.

Optional synchronous generator protection.

Integrated Automatic Synchronizer Option

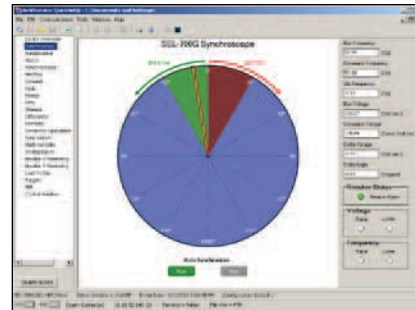

Automatically adjusts generator voltage, speed, and phase angle to match line voltage. Closes breaker when synchronized.

Substation-Hardened Ethernet

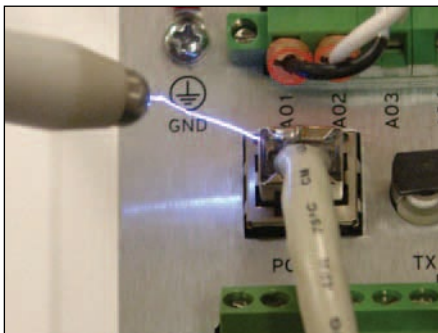

Modbus® TCP, SNMP, DNP3 LAN/WAN, Telnet, FTP, and IEC 61850.

Fiber or copper Ethernet communications port.

Withstands electrostatic air discharge of 15 kV.

Industry-Leading Quality, Reliability, and Service





Functional Overview

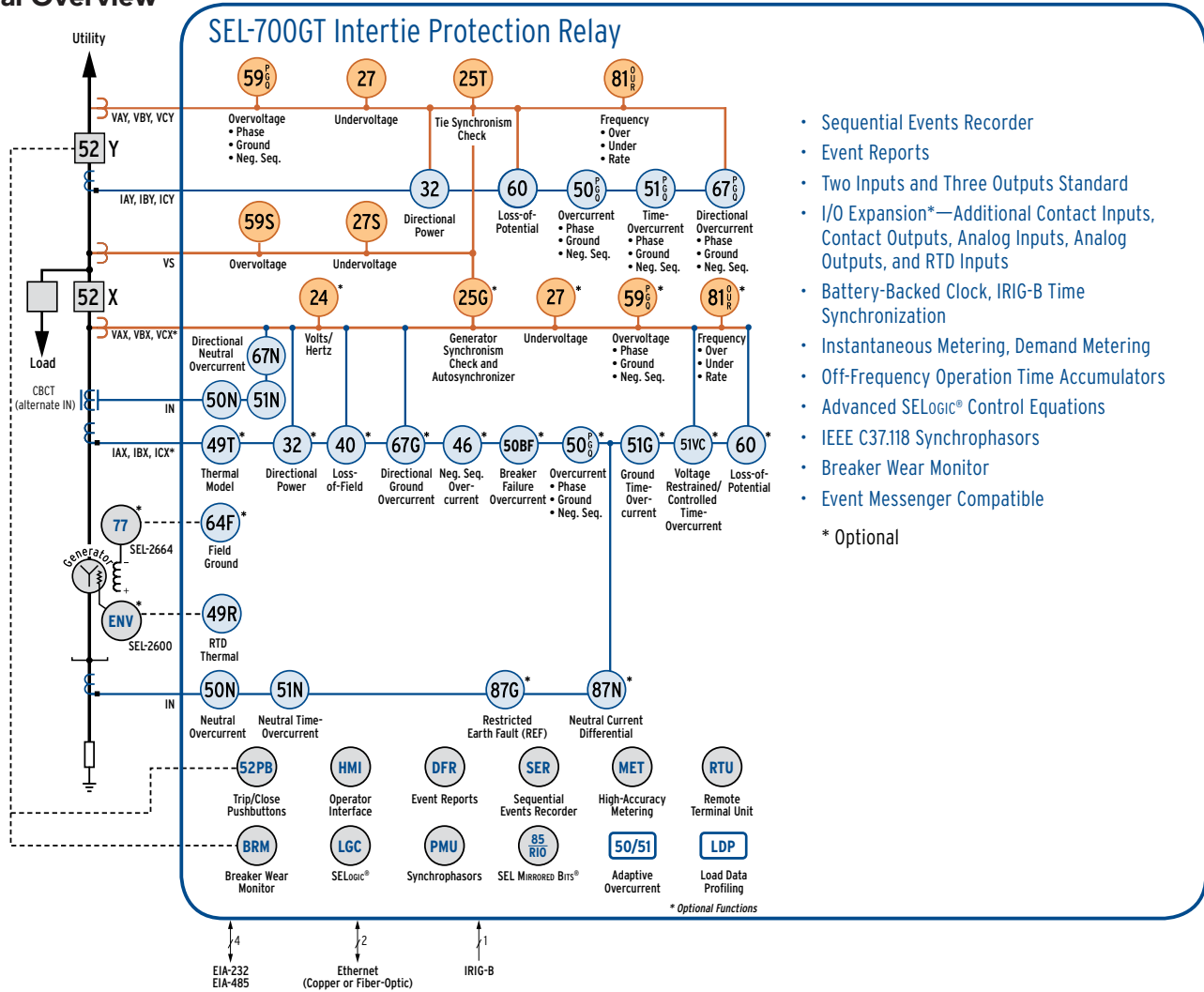

- Sequential Events Recorder
 - Event Reports
 - Two Inputs and Three Outputs Standard
 - I/O Expansion*—Additional Contact Inputs, Contact Outputs, Analog Inputs, Analog Outputs, and RTD Inputs
 - Battery-Backed Clock, IRIG-B Time Synchronization
 - Instantaneous Metering, Demand Metering
 - Off-Frequency Operation Time Accumulators
 - Advanced SELLogic® Control Equations
 - IEEE C37.118 Synchrophasors
 - Breaker Wear Monitor
 - Event Messenger Compatible
- * Optional

Feature Overview

Use default messages, or program up to 32 custom display labels.

Use default pushbuttons, or program your own pushbutton actions and labels.

Front-panel LEDs can be programmed to indicate custom alarms.

User-configurable label option.



Power supply options include:
24-48 Vdc
110-250 Vdc
110-240 Vac

Single or dual, copper or fiber-optic Ethernet port.

Positions for optional expansion cards.

Voltage and current inputs.

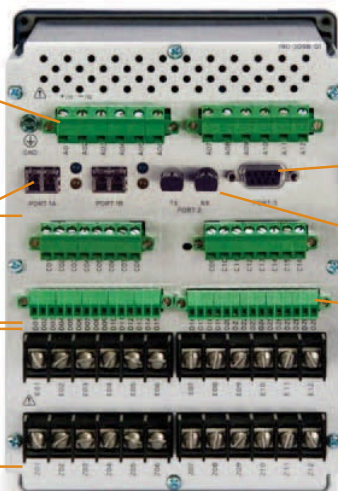

MIRRORED BITS® communications.

Fiber-optic serial port.

Optional RTD inputs.



Applications

Complete Intertie and Generator Protection

The SEL-700GT provides a complete intertie protection solution for distributed generation. Optional synchronous generator protection and synchronization provide complete generator and intertie protection in one compact and economical package.

The optional SEL-2664 Field Ground Module accurately detects field ground faults whether the generator is operating, stopped, or de-energized.

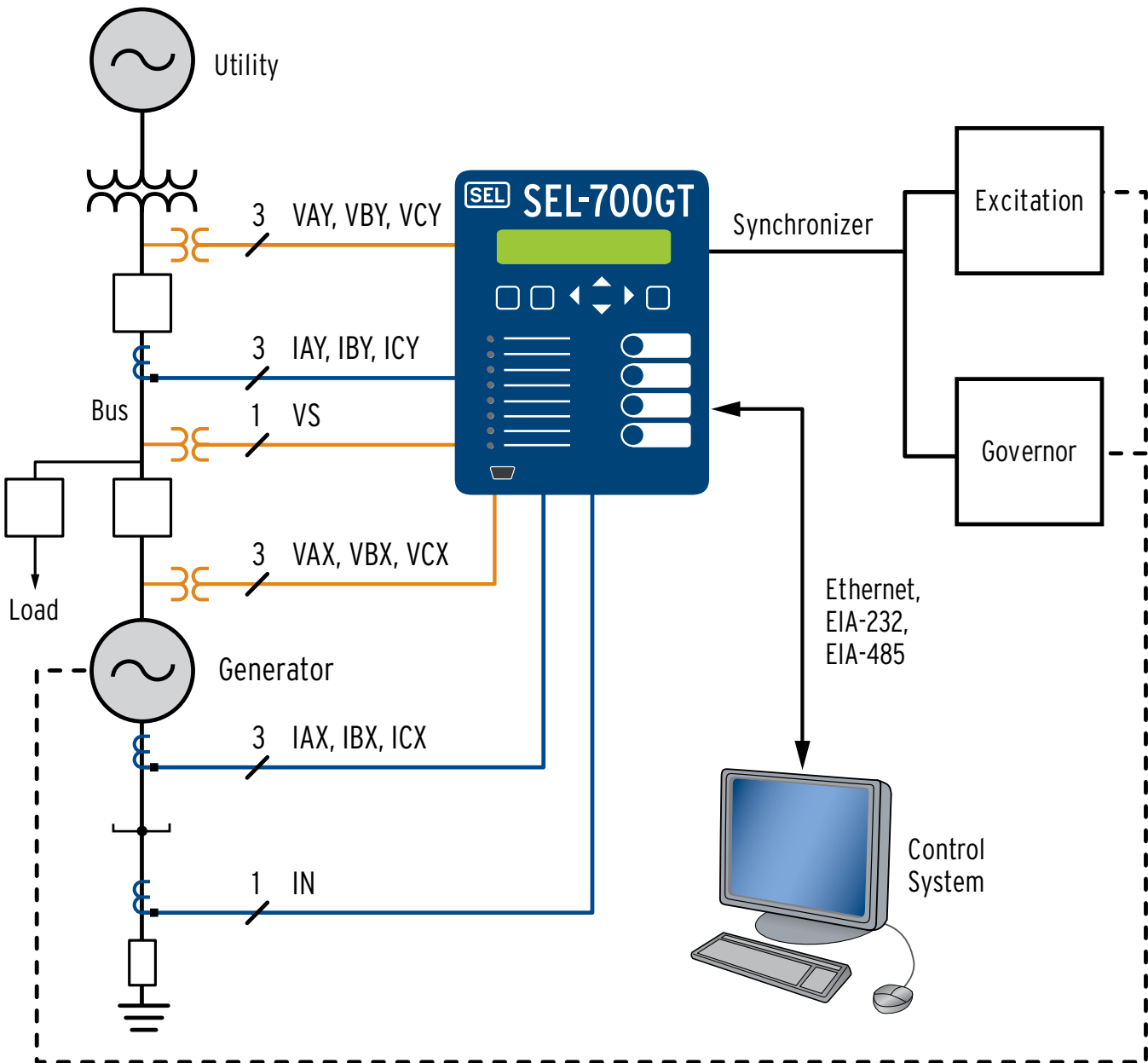

The application shown includes optional generator protection and synchronism-check voltage input (VS). Ethernet and EIA-485 are optional. Also available are RTD and field ground module (SEL-2664) inputs (not shown).



SEL-700GT Intertie Protections Relay"
Easy to Set and Use

Use **acSELEATOR QuickSet® SEL-5030 Software to Set, Monitor, and Control the SEL-700GT**

- Save engineering time while keeping flexibility. Communicate with the SEL-700GT through any ASCII terminal, or use the acSELEATOR QuickSet graphical user interface.
- Develop settings offline with a menu-driven interface and completely documented help screens. Speed installation by copying existing settings files and modifying application-specific items.
- Simplify the settings procedure with rules-based architecture to automatically check interrelated settings. Out-of-range or conflicting settings are highlighted for correction.
- Use the acSELEATOR HMI synchroscope to view the real-time synchronization process.
- Initiate the generator synchronization process using an HMI pushbutton.

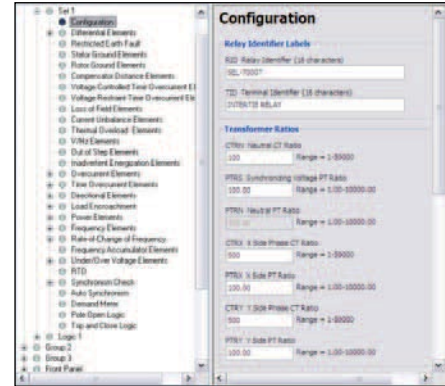

Use **acSELEATOR Software to Retrieve and Display Event Reports Recorded by the SEL-700GT**

- Display event report oscillograms. View each report as a plot of magnitude versus time. Select analog and digital points to build a custom display.
- Display phase and symmetrical component phasors. Display the phasor view of electrical data to better understand asymmetrical, three-phase faults. Build a custom plot using per-phase and symmetrical component sequence currents and voltages.
- Retrieve event reports using serial or Ethernet communications links.

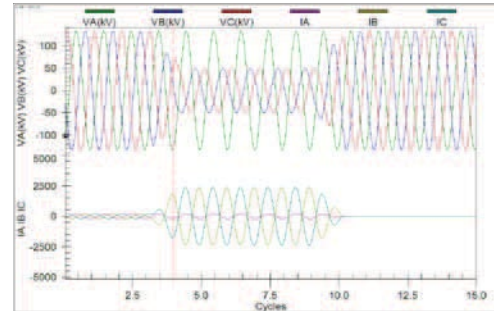

Flexible Communication

Communications Media

- Ethernet 10/100BASE-T
- Ethernet 100BASE-FX
- Single or dual Ethernet ports
- EIA-232 serial
- EIA-485 serial
- Fiber-optic, serial multimode ST®

Communications Protocols

- SEL ASCII
- MIRRORRED BITS communications
- IEC 61850
- Modbus RTU/TCP
- Simple Network Time Protocol (SNTP)
- DNP3 serial, LAN/WAN
- DeviceNet™
- Telnet
- FTP
- Synchrophasors (IEEE C37.118)

Mounting Options

Retrofit Replacement Kits

Replace existing generator protection with the SEL-700GT and the applicable mounting kit. These kits provide everything needed to replace many existing generator relays with the SEL-700GT.

No cutting or drilling is required when you use the optional mounting kits. Replacement of existing protection is quick and easy!

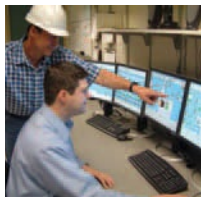

Central control room.



Field remote terminal.

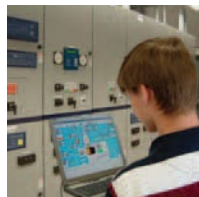

Engineering access.



NOTE:
SOME PANELS HIDDEN FOR CLARITY

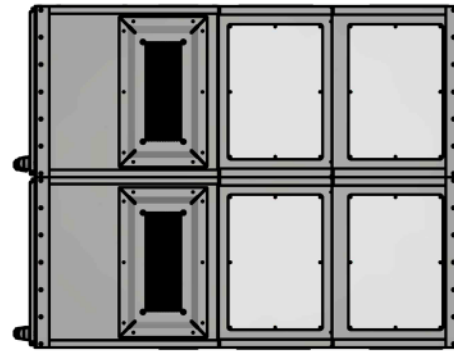

TOP VIEW

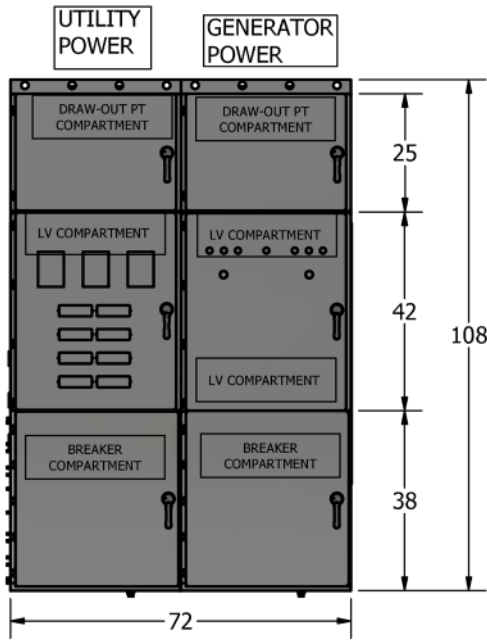

FRONT VIEW

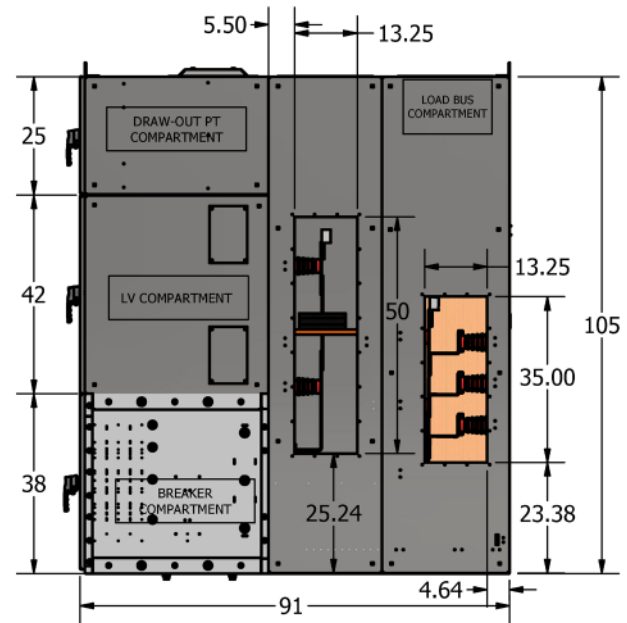

SIDE VIEW

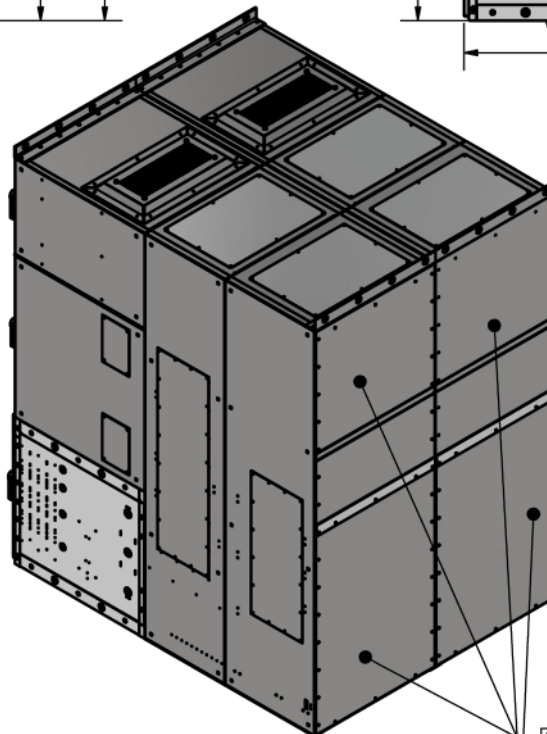

ISO VIEW

REMOVABLE REAR COVERS



SECTION 5 RELAY FRONT PANEL CONFIGURATION

5.1 SEL-700GT TARGET LEDs AND FRONT PANEL PUSHBUTTONS

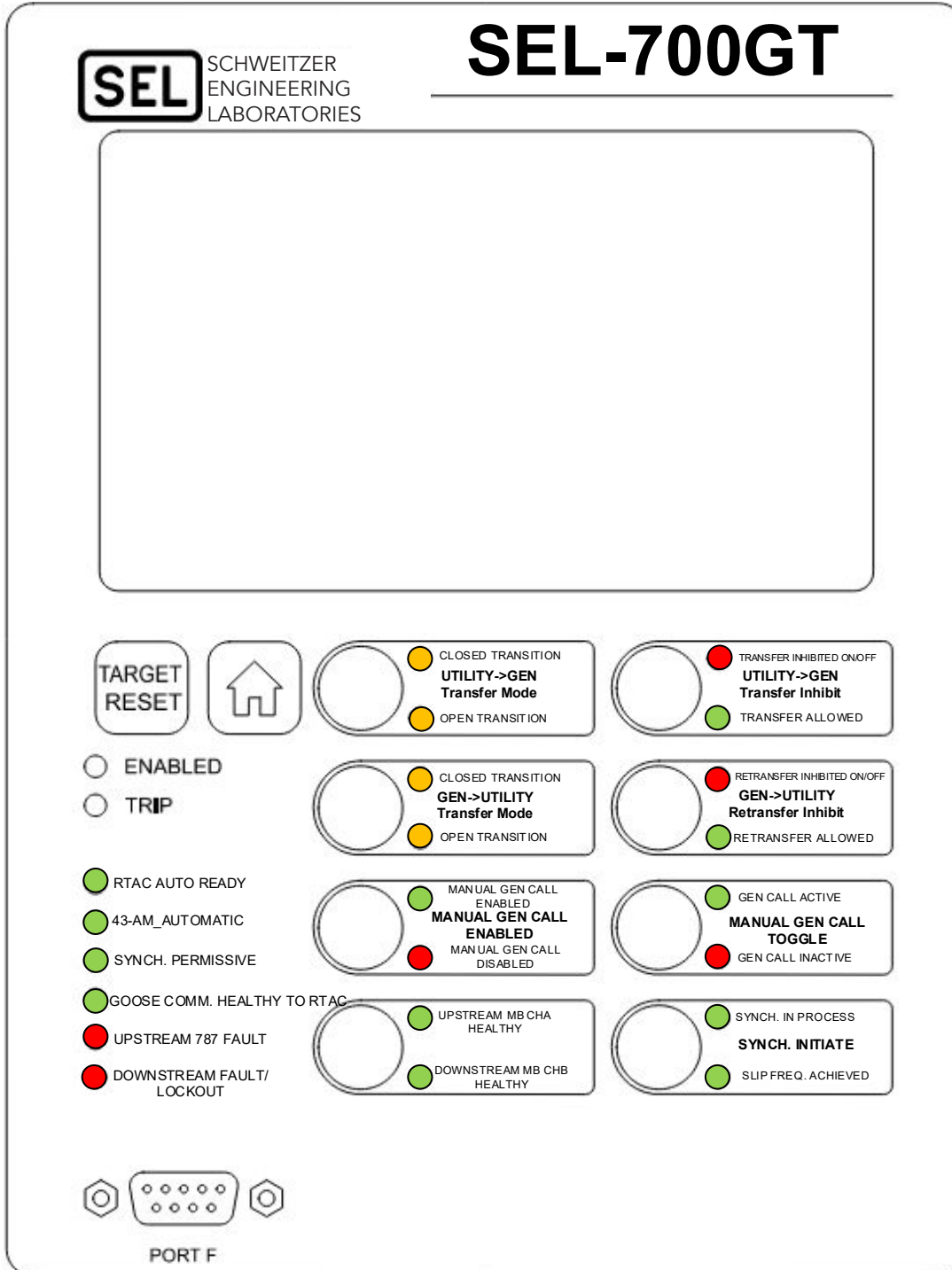

Figure 5-1: Relay Front Panel

* This is our standard push button configuration that can be customized and relabeled for various applications.



SAFE SYNC
AUTOMATIC TRANSFER SWITCH

Sales Flyer



Spike Electric Controls
5914 E. Sam Houston Pkwy S.
Houston TX 77034

Toll Free 1.844.279.8295 • Local Factory Support 832.243.5372 • Fax 832.569.5645
sales@spikeelectric.com spikeelectric.com

Copyright © 2023 Spike Electric Controls