

# EJB, Style C Model M82 Series Junction Boxes

## Installation & Maintenance Information

**SAVE THESE INSTRUCTIONS FOR FUTURE REFERENCE**

### APPLICATION

EJB Series Junction Boxes are used as a junction box or pull box in rigid conduit systems.

EJB Series Junction Boxes are suitable for use indoors or outdoors and are UL Listed and CSA Certified for Class I, Groups B, C, D; Class II, Groups E, F, G; and Class III hazardous (classified) areas as defined by the National Electrical Code® and the Canadian Electrical Code®, and include a gasket to meet Type 4 watertight requirements.

EJB Series classified enclosures ordered with suffix -ATEX meet the ATEX directive and are certified by ETL. EJB classified enclosures with -ATEX suffix have the following classification: (Ex) II 2 G Ex d IIB + H2. ATEX certified boxes have an IP 66 rating. ATEX suffix junction box complies with EN60079-0:2006 and EN60079-1:2006 Certificate ITS08 ATEX 15797U. ATEX certified boxes cannot be field drilled and tapped for entries. All entries must be drilled and tapped by Cooper Crouse-Hinds at the factory.

EJB Series Junction Boxes should be installed, inspected and maintained by qualified and competent personnel.

### INSTALLATION

**⚠ WARNING**

1. Electrical power must be off before and during installation and maintenance.
2. Field modification of this product is not permitted other than drilled and tapped conduit entries per these instructions.

1. EJB Series Junction Boxes are furnished with or without drilled and tapped openings. Drilling and tapping of conduit openings is subject to the limitations of maximum size and

number of openings as well as spacings. Refer to DRILLING AND TAPPING section following. All machining must be done prior to installation.

2. Select a mounting location that will provide suitable strength and rigidity for supporting all contained wiring and control devices. Figure 1 shows the mounting dimensions for the four detachable mounting feet.

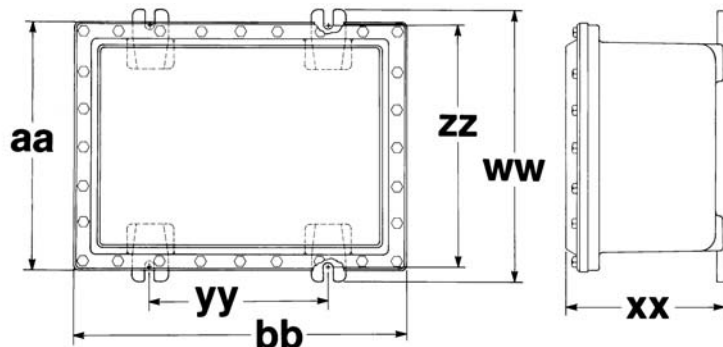

**IMPORTANT**  
ATEX certified boxes **MAY NOT** be field drilled and tapped. Entries must be machined by factory.

Catalog No.	DIMENSIONS (in.)								Net Wt. w/Cover (Lb.)
	Inside Depth **	aa	bb	Mtg. Hole	ww	zz	yy	zz	
EJB100806	6-3/8	13-1/32	15-1/32	9/16	12-1/4	8-9/16	5-1/2	11-1/4	60
121204	4-13/16	17-1/16	17-1/16	9/16	16-1/8	6-15/16	5-1/2	15-1/8	60
121206	6-13/16	17-1/16	17-1/16	9/16	16-1/8	8-9/16	5-1/2	15-1/8	70
121208	8-13/16	17-1/16	17-1/16	9/16	16-1/8	10-9/16	5-1/2	15-1/8	80
161606	6-11/16	21-3/16	21-3/16	9/16	20-1/4	8-9/16	9-1/2	19-1/8	103
161608	6-11/16	21-3/16	21-3/16	9/16	20-1/4	10-9/16	9-1/2	19-1/8	113
181206	8-11/16	17-5/16	23-5/16	9/16	16-3/8	8-9/16	11-1/2	15-1/8	101
181208	6-13/16	17-5/16	23-5/16	9/16	16-3/8	10-9/16	11-1/2	15-1/8	110
241208	9-1/4	17-9/16	29-9/16	9/16	16-5/8	11-5/16	17-1/2	15-1/8	149
241210	11-1/4	17-9/16	29-9/16	9/16	16-5/8	13-5/16	17-1/2	15-1/8	160
241808	8-3/4	23-9/16	29-5/8	11/16	23-1/2	11-13/16	17-1/4	21-7/8	243
241810	10-3/4	23-9/16	29-5/8	11/16	23-1/2	13-13/16	17-1/4	21-7/8	258
242408	8-7/16	23-9/16	29-9/16	11/16	29-1/2	11-13/16	16-1/4	27-7/8	296
242410	10-7/16	23-9/16	29-9/16	11/16	29-1/2	13-13/16	16-1/4	27-7/8	322
361208	8-5/8	16-5/16	40-5/16	9/16	16-1/8	11-5/8	29-1/2	15-1/8	185
361808	8-5/8	23-15/16	41-15/16	11/16	23-3/4	11-7/8	28-1/4	21-7/8	357
361810	10-5/8	23-15/16	41-15/16	11/16	23-3/4	14-1/4	28-1/4	21-7/8	396
362408	8-1/4	30-3/16	42-3/16	11/16	30-3/8	12-3/4	28-1/4	28-1/2	571

\*Body and Cover

**Figure 1. EJB-M82 Dimensions**

© National Electrical Code is a Register Trademark of the National Fire Protection Association.

© Canadian Electrical Code is a voluntary code for Adoption and Enforcement by Regulatory Authorities.

3. Install detachable mounting feet.
  - Insert four wedge shaped mounting feet into dove-tail slots in enclosure body.
  - Tap each foot to securely tighten into slot.

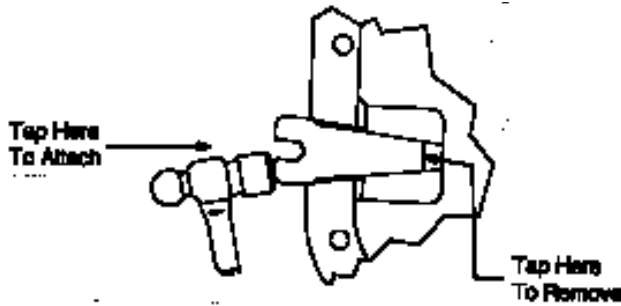

**Figure 2. Mounting Feet**

4. Securely fasten enclosure to the mounting location, then attach into conduit system. Install approved conduit sealing fittings when required by Section 501.15 and/or 502.15 of the National Electrical Code plus any other applicable standards.

**⚠ CAUTION**

- Hazardous location information specifying class and group listing of each device is marked on the nameplate of each enclosure. Class and group listing for any device penetrating the enclosure must be suitable for the classification of the location in which the enclosure is installed.
- All unused conduit openings must be plugged. Listed plug must engage a minimum of five full threads and be a minimum of 1/8 inch thick.
- In Class I, Division 1, Group B locations, conduit sealing fittings **MUST** be installed in each attached conduit run (within eighteen inches of the enclosure) to comply with the latest edition of the National Electrical Code Section 501.15 and/or 502.15 plus any other applicable code.
- Conduit sealing fittings are required on all conduit entrances (within eighteen inches of the enclosure) for EJB361208, EJB361808, EJB361810 and EJB362408 enclosures when used in Class I, Div. 1, Group C hazardous areas. For other sealing requirements, consult the National Electrical Code®.

**⚠ CAUTION**

Do not use cover bolts as a means to lift the enclosure. Excessive force on the fully retracted cover bolts may damage the bolt/spring assembly.

5. Loosen all cover bolts until each bolt is fully retracted into the cover by the stainless steel spring under the bolt head. Remove the nuts from two stud bolts, then lift off cover and carefully set it aside to prevent damage to the ground joint and flange gasket.

**NOTE:** EJB junction boxes without cover hinges have two stud bolts located at diagonally opposite corners of the body to aid in positioning cover. Do not remove stud bolts. Covers may be handled more easily by installing two 5/8-11 triple lead eyebolts into the two threaded holes provided in the cover. The eyebolts should only be threaded part way through the cover to prevent damage to the machined flange of the body.

EJB enclosures are furnished with captive triple lead bolts, that utilize a spring to aid and indicate full retraction of the bolts into the cover when opening and closing. Make sure all cover bolts are fully retracted into the cover before attempting to open or close the cover.

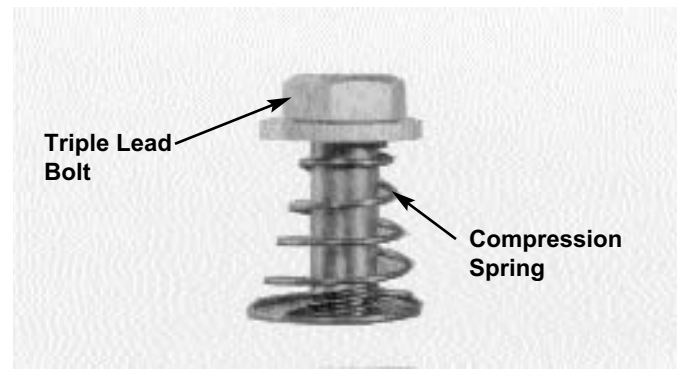

**Figure 3**

When bolts are disengaged from the body flange threads, the bolts will withdraw and be held in this position by the spring and washer under the bolt heads. (See Figure 3).

After all bolts are fully disengaged, firmly grasp the bottom and right side of the cover and carefully swing cover aside to prevent damage to the ground joint surface. Avoid striking cover, or devices in cover, on neighboring enclosures or structures.

**⚠ CAUTION**

Hammers or prying tools must not be allowed to damage the flat ground-joint surfaces or cover gasket. Do not handle covers roughly, or place them on surfaces that might damage or scratch the flat ground-joint surfaces.

6. Pull wires into enclosure, making sure they are long enough to make the required connections. Make all electrical connections. The internal grounding terminal shall be used as equipment grounding means. The external terminal is only a supplemental bonding connection.
7. Test wiring for correctness with continuity checks and also for unwanted grounds with insulation resistance tester.

**⚠ CAUTION**

Clean both ground-joint surfaces of body and cover before closing. Dirt or foreign material must not accumulate on flat ground joint surfaces. Surfaces must seat fully against each other to provide a proper explosionproof seal.

8. To install cover, make sure cover and body ground-joint surfaces are clean and not scratched. Orient cover to align with two stud bolts on body. Lift cover to approximate position, and line up bolt holes of cover with body. **Avoid** sliding cover ground joint surface over ground joint surface of body. Cover/body bolt holes must match up. Hand start the corner bolts. Fully tighten all cover bolts (torque to 40-45 ft. lbs.) and then reinstall the two 5/16 - 18 hinge bolts (torque to **8 ft. lbs.**) in the cover.
9. Pour sealing compound into sealing fittings (when required) in accordance with the instructions supplied with each of the approved fittings and sealing compound.

**BREATHER AND DRAIN**

**⚠ CAUTION**

Check breather and/or drain or their carton label to be certain that they are suitable for the hazardous location (class and group) and environmental rating as marked on the enclosure nameplate.

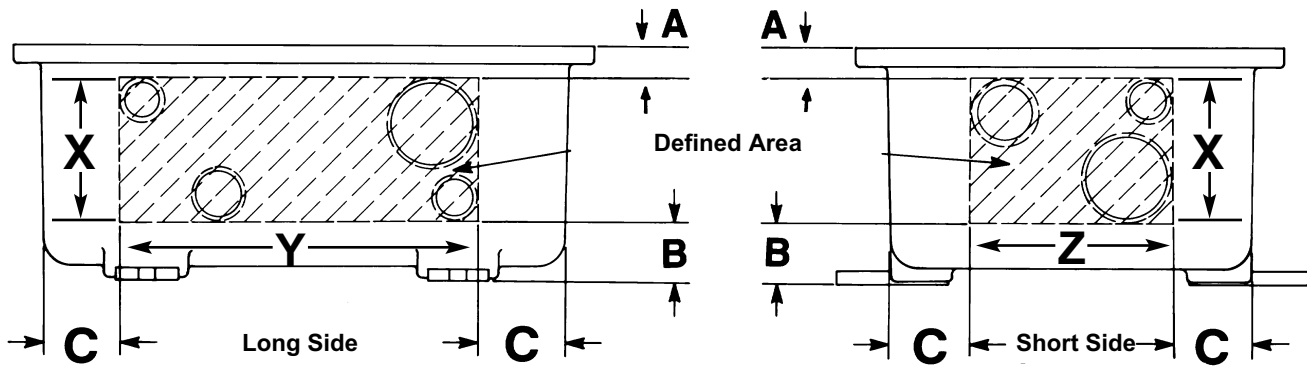

Catalog Number	Maximum* Size of Drilled and Tapped Conduit Openings								Outlined Dimensions Defined Area			Dimensions Defined Area		
	Long Side				Short Side				A	B	C	X	Y	Z
	Number of Openings				Number of Openings									
1	2	3	4	1	2	3	4							
EJB100806	3-1/2	3	1-1/2	1-1/4	3-1/2	2-1/2	1-1/4	3/4	1-1/8	1-3/4	1-1/4	4.46	9.25	7.25
EJB121204	1-1/2	1-1/2	1-1/2	1-1/4	1-1/2	1-1/2	1-1/2	1-1/4	1-1/8	1-3/4	1-1/4	2.38	11.31	11.31
EJB121206	3-1/2	3-1/2	1-1/2	1-1/4	3-1/2	3-1/2	1-1/2	1-1/4	1-1/8	1-7/8	1-1/4	4.32	11.13	11.13
EJB121208	5	3-1/2	1-1/2	1-1/4	5	3-1/2	1-1/2	1-1/4	1-1/8	1-7/8	1-1/4	6.38	11.06	11.06
EJB161606	3-1/2	3-1/2	2-1/2	2	3-1/2	3-1/2	2-1/2	2	1-1/8	2	1-1/4	4.19	15.13	15.13
EJB161608	5	5	3	2	5	5	3	2	1-1/8	2	1-1/4	6.19	15.06	15.06
EJB181206	3-1/2	3-1/2	3-1/2	2-1/2	3-1/2	3-1/2	1-1/2	1-1/4	1-1/8	2	1-1/4	4.23	16.50	10.50
EJB181208	5	5	3-1/2	2-1/2	5	3-1/2	1-1/2	1-1/4	1-1/8	2	1-1/4	6.22	16.44	10.44
EJB241208	5	5	5	3-1/2	5	3-1/2	1-1/2	1-1/4	1-7/16	2	1-3/8	5.97	23.43	11.43
EJB241210	6	6	5	3-1/2	6	3-1/2	1-1/2	1-1/4	1-7/16	2	1-3/8	7.97	23.36	11.36
EJB241808	5	5	5	3-1/2	5	5	3-1/2	2-1/2	1-7/16	2-5/8	1-3/8	5.85	23.08	17.06
EJB241810	6	6	5	3-1/2	6	6	3-1/2	2-1/2	1-7/16	2-5/8	1-3/8	7.85	23.01	17.01
EJB242408	5	5	5	3-1/2	5	5	5	3-1/2	1-7/16	2-11/16	1-3/8	5.85	23.08	23.08
EJB242410	6	6	5	3-1/2	6	6	5	3-1/2	11-7/16	2-11/16	1-3/8	7.85	23.01	23.01
EJB361208	5	5	5	5	5	3-1/2	1-1/2	1-1/4	1-7/16	2	1-3/8	5.92	34.97	10.97
EJB361808	5	5	5	5	5	5	3-1/2	2-1/2	1-7/16	2-13/16	1-3/8	5.83	35.08	17.08
EJB361810	6	6	5	5	6	6	3-1/2	2-1/2	1-7/16	2-5/16	1-5/8	8.29	35.40	17.40
EJB362408	5	5	5	5	5	5	5	3-1/2	1-7/16	3-1/4	2	5.56	35.05	23.05

TABLE 1

Consult Crouse-Hinds for proper space for installing and servicing fittings such as seals, unions, GUA's, etc.

\*Maximum conduit size permitted in Group B locations is 4".

**DRILLING AND TAPPING FOR ENTRIES**

(ATEX Certified boxes must have all drilled and tapped entries machined at Cooper Crouse-Hinds factory)

- To comply with the NEC sections 344.28 and 344.46, all conduit entries must be provided with a smooth rounded entry into the enclosure. This may be accomplished in various ways, including the use of Crouse-Hinds RE reducers or by using LNR series conduit liners.

The location and maximum sizes of conduit openings must be in accordance with Table 1.

- Female conduit must be taper tapped with the thread form and taper (3/4 in. per ft.) conforming to NPT. A standard NPT male gage must enter the tapped opening 1-1/2 turns past the gage notch. Openings are tapped deeper than standard NPT gage to ensure a minimum of five full threads engagement with standard NPT threaded conduit (refer to NEMA FB-1-4.01).
- Conduit entries in the back wall are permissible for the EJB1212 size enclosure only. See Figure 4 for the maximum size and quantity of entries. If more entries are needed, use the 1 1/2" substitution data in Table 2. Use Table 3 for minimum spacing of conduit entries.

**NOTE:** Side wall entries are not allowed in combination with back wall entries.

If more than four (4) conduit entries, or a mix of conduit entry trade sizes are needed in any wall of the enclosure, use the following instructions:

- From Table 1, determine how many 5" conduit entries are permitted on a side. ‡ For example, a quantity of (4) 5" entries are permitted on the long side of an EJB361808.
- For each 5" conduit entry permitted ‡, one may substitute a quantity of smaller conduit entry trade sizes.
- Some smaller enclosures cannot accept a 5" opening, in which case, the maximum number of 3 1/2" or 1 1/2" conduit openings must be determined (again, using Table 1).
- Use Table 2 to determine how many of the smaller conduit entries may be substituted for either the 5", the 3 1/2" or the 1 1/2" trade size. Use Table 3 for minimum spacing of conduit entries.

Basis of Substitution	1/2"	3/4"	1"	1 1/4"	1 1/2"	2"	2 1/2"	3"	3 1/2"	4"	5"
5"	9	7	7	4	3	2	1	1	1	1	1
3 1/2"	5	4	3	2	1	1	1	1	1	0	0
1 1/2"	2	2	1	1	1	0	0	0	0	0	0

TABLE 2

Number and size of smaller conduit entries which may be substituted for 5" or 3 1/2" entries.

‡ These instructions can be used for Group B locations, provided no entry machined in the wall of the enclosure exceeds 4" trade size.

DRILLED AND TAPPED CONDUIT OPENINGS MINIMUM CENTER-TO-CENTER DISTANCE (IN.)												
Conduit Size	1/2	3/4	1	1-1/4	1-1/2	2	2-1/2	3	3-1/2	4	5	6
1/2	1-1/2											
3/4	1-5/8	1-3/4										
1	1-3/4	1-7/8	2									
1-1/4	2	2-1/8	2-1/4	2-1/2								
1-1/2	2-1/8	2-1/4	2-3/8	2-5/8	2-3/4							
2	2-3/8	2-1/2	2-5/8	2-7/8	3	3-1/4						
2-1/2	2-3/4	2-7/8	3-1/8	3-1/4	3-3/8	3-5/8	3-7/8					
3	3-1/8	3-1/4	3-3/8	3-1/2	3-5/8	4	4-1/4	4-5/8				
3-1/2	3-3/8	3-1/2	3-5/8	3-7/8	4	4-1/4	4-1/2	4-7/8	5-1/8			
4	3-3/4	3-7/8	4	4-1/8	4-1/4	4-1/2	4-7/8	5-1/8	5-3/8	5-3/4		
5	4-3/4	4-7/8	5	5-1/8	5-1/4	5-1/2	5-3/4	6-1/8	6-3/8	6-5/8	7-1/4	
6	5-1/4	5-3/8	5-1/2	5-3/4	5-7/8	6-1/8	6-3/8	6-5/8	6-7/8	7-1/8	7-3/4	8-1/4

Minimum clearance for unions only.  
TABLE 3

METRIC EQUIVALENTS	
NPT Conduit Size	Metric Openings
1/2	M16 x 1.5
3/4	M20 x 1.5
1	M25 x 1.5
1-1/4	M32 x 1.5
1-1/2	M40 x 1.5
2	M50 x 1.5
2-1/2	M63 x 1.5
3	M75 x 1.5
3-1/2	M90 x 2.0

TABLE 4

- Metric openings must be in accordance with Table 4 and have a class 6H fit (refer to ISO 965-1 and ISO 965-3). In Division 1 Group B areas, fittings must have a minimum of eight full threads engagement. In Division 1 Group C, D areas, fittings must have a minimum of five full threads engagement. The location, quantity, and maximum sizes of metric openings must be in accordance with Table 1. Use Table 4 to determine the equivalent NPT sizes.

**Note:** Per NEC and UL requirements, all metric entries must be permanently marked and identified, or listed metric to NPT adapters provided, or metric cable glands must be used.

- For conduit entries with non-interfering vertical seals: center-to-center distance is the total of: 1/2 the outside diameter of the larger conduit plus the turning radius of the sealing fitting used in the smaller conduit plus 1/4 inch clearance.
- For conduit entries with non-interfering horizontal seals: center-to-center distance is the total of: 1/2 the outside diameter of the larger conduit plus the turning radius of the sealing fitting used in the smaller conduit plus 2 inches clearance for pouring.

**CAUTION**

While the number of openings derived from the above will result in a safe configuration, the number of openings could be reduced if center-to-center spacings were required to be increased for the following reason:

- If sealing fittings are required to be installed in the conduit, sufficient room must be provided to install, pack, and pour the fitting after the conduit and fittings are installed and the conductors are in place. This is particularly important in horizontal conduit runs, when fittings are directly over one another.

**CAUTION**

The space between drilled & tapped conduit entries is a factor of the following considerations:

- Ability to install conduit with a variety of fittings (for various reasons, the conduit which is to be threaded into each conduit entry may, in turn, be threaded into a variety of fittings including (but not limited to) the following: unions, sealing fittings of various types, and GUA type fittings. Dimensions of these fittings are provided in the Crouse-Hinds catalog, and should be referred to in planning a conduit layout).
- All drilled and tapped conduit entries must fall completely within the defined areas as specified in Table 1.

**FOR ATEX ENCLOSURES:**

- Before opening the enclosure in a flammable atmosphere, circuits must be interrupted.
- The approval applies to equipment without cable glands. When mounting

the flameproof enclosure in a hazardous area, only rigid metal conduit systems or flameproof cable glands certified to EN60079 must be used.

- All unused conduit entries must be closed with a flameproof plug certified to EN60079.
- Any components attached or installed (e.g. terminal compartments, bushings, explosionproof cable entries, connectors) shall be of a technical standard that complies with the specifications on the cover sheet as minimum and for which a separate type examination certificate has been issued. The operating conditions set forth in the relevant component certificates must by all means be complied with.

Securely fasten enclosure to the mounting location, then attach into conduit system.

The EJB shall be connected by means of suitable cable entries or conduit systems, which meet the requirements of EN60079-1, Sections 13.1 and 13.2, and for which a separate type examination certificate has been issued.

Terminate ground wire with 3/16" ring terminal appropriately sized for ground wire gauge (10 AWG minimum). Install ground wire such that it cannot become loose or twisted.

The enclosure is intended for wiring connections only, or for controller devices or other equipment which fall within the electrical parameters indicated above.

**Note:** Cable entries as well as sealing plugs of simple construction must not be used.

Cable entries (conduit threads) and sealing plugs of simple designs must not be used. Should the EJB be connected by means of a conduit entry which has been approved for this purpose, the required sealing device shall be provided immediately at the terminal box.

Any openings not used shall be sealed as specified in EN60079-0, Section 13.3.

The connecting wire of the EJB shall be installed to provide for permanent wiring and adequate protection against mechanical damage.

If the temperature at entry fittings should exceed 70°C, the connecting cables used have to be of the temperature-resistant type.

**MAINTENANCE**

**WARNING**

Always disconnect primary power source before opening enclosure for inspection or service.

- Frequent inspection should be made. A schedule for maintenance check should be determined by the environment and frequency of use. It is recommended that it should be at least once a year.
- Perform visual, electrical, and mechanical checks on all components on a regular basis.
  - Visually check for undue heating evidenced by discoloration of wires or other components, damaged or worn parts, or leakage evidenced by water or corrosion in the interior.
  - Electrically check to make sure that all connections are clean and tight and that contacts in the components make or break as required.
  - Mechanically check that all parts are properly assembled and operating mechanisms move freely.
- EJB gasketed junction boxes: do not attempt field replacement or repair of cover gasket. Instead, remove damaged gasket and continue to use cover without gasket. This will assure safety for use in Class I and Class II hazardous (classified) locations. However, the enclosure will **not** be watertight.

**CAUTION**

Clean both ground-joint surfaces of body and cover before closing. Dirt or foreign material must not accumulate on flat ground-joint surfaces. Surfaces must seat fully against each other to provide a proper explosionproof seal.

Cooper Crouse-Hinds recommends an Electrical Preventative Maintenance Program as described in the National Fire Protection Association Bulletin NFPA 70B.

**REPLACEMENT PARTS:**

EJB, Style C Model M82 Series Junction Boxes are designed to provide years of reliable service. However, should the need for replacement parts arise, they are available through your Cooper Crouse-Hinds Distributor. Assistance may also be obtained through your Cooper Crouse-Hinds Sales Representative or the Cooper Crouse-Hinds Customer Service Department.

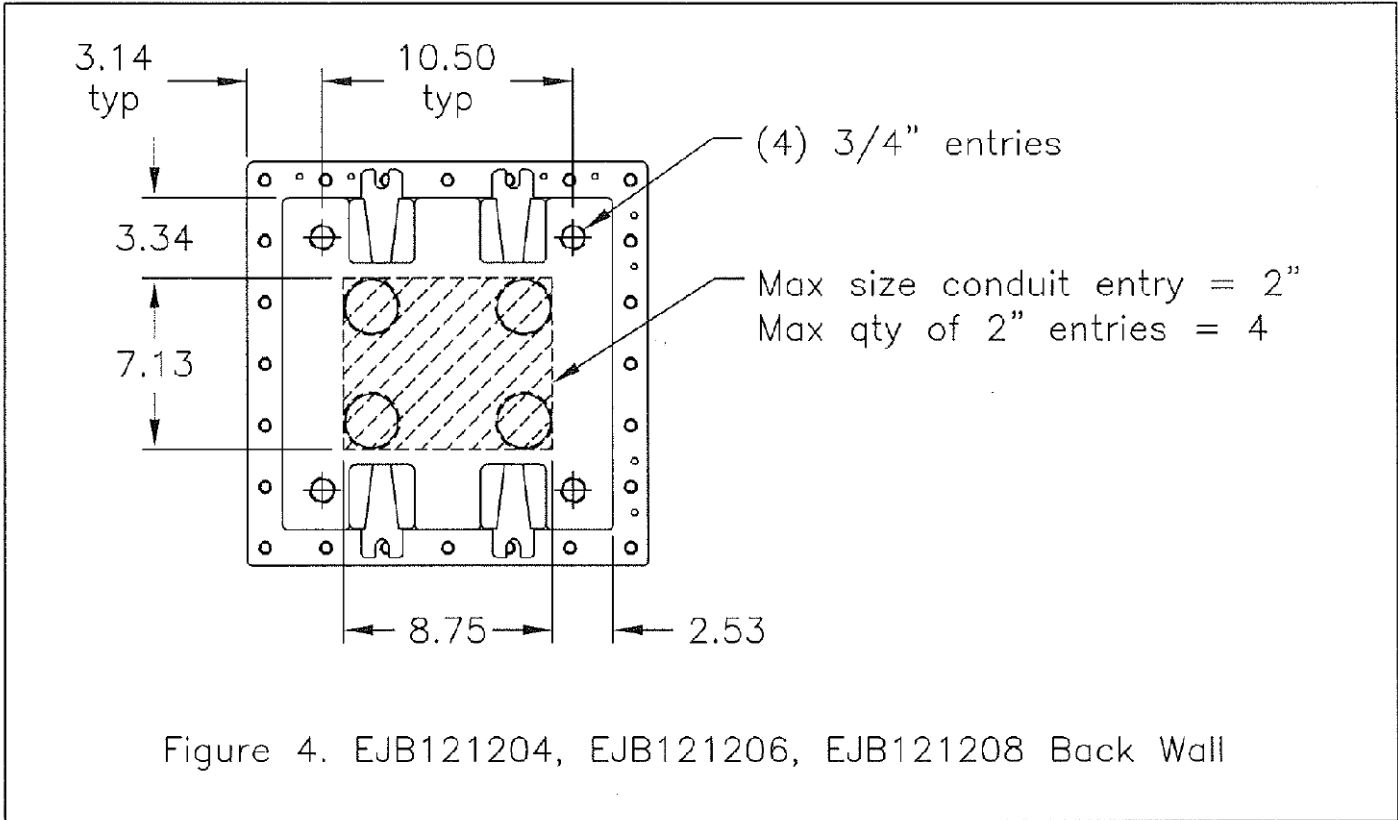

All statements, technical information and recommendations contained herein are based on information and tests we believe to be reliable. The accuracy or completeness thereof are not guaranteed. In accordance with Crouse-Hinds "Terms and Conditions of Sale," and since conditions of use are outside our control, the purchaser should determine the suitability of the product for his intended use and assumes all risk and liability whatsoever in connection therewith.