

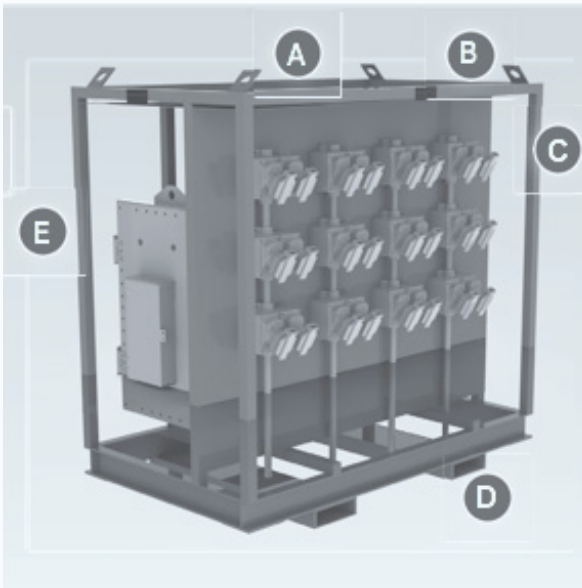

Power Carts Hazardous and Non Hazardous



CONTACT US:

1.844.279.8295 - Toll Free

832.243.5372 - Local Factory Support

832.569.5645 - Fax

factoryassistance@spikeelectric.com

spikeelectric.com

5914 E. Sam Houston Pkwy S.

Houston TX 77034

Copyright © 2018 Spike Electric Controls

Power Carts

Hazardous and Non Hazardous

Solutions designed for industrial and hazardous applications

Plant turnarounds can be complex, chaotic, and costly events. During your next shutdown, turn to Eaton's Crouse-Hinds for safe, reliable electrical power equipment that ensures efficient and successful operations.

- UL1640 compliant
- 2-wheel, 4-wheel, and skid options
- Standardized cart sizes reduce lead times and eliminate potential on-site placement issues
- Hazardous area power carts eliminate need for time-consuming area declassification and equipment monitoring

2-Wheel Power Carts:

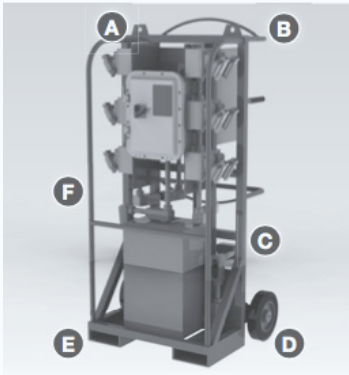

Design Features

- A** Lifting Eyes
- B** Power Cord Holder
- C** Durable & Robust Carbon Steel Frame
- D** Pneumatic, Simi-Pneumatic, or Solid Rubber Wheel Options
- E** Forklift Confinement Tubes
- F** Enclosed Design Protects Components

Technical Specifications:

Hazardous			Industrial Non-Hazardous		
Specifications			Specifications		
Primary Voltage: 240 – 600V	Max Secondary Current: 225A		Primary Voltage: 240 – 600V	Max Secondary Current: 225A	
Max Primary Current: 100A	Max Secondary Current w/ Main: 100A		Max Primary Current: 100A	Max Secondary Current w/ Main: 225A	
Max Secondary Voltage: 240V			Max Secondary Voltage: 480V		
Compatible Components			Compatible Components		
Receptacles	Transformers	Panelboards	Receptacles	Transformers	Panelboards
ENR	7.5 kVA	EJB 12 circuit	CPS AR	7.5 kVA	18 circuit
CPS	9 kVA		ENR WSQC	9 kVA	30 circuit
CES	10 kVA	Disconnects	CES WLRS	10 kVA	
FSQC	15 kVA	EIB	FSQC WLRD	15 kVA	Disconnects
			Water tight	25 kVA	30A, 60A, 100A
			Twist lock		

Cart/Skid Sizes:



Power Carts

Hazardous and Non Hazardous

4-Wheel Power Carts and Skids:

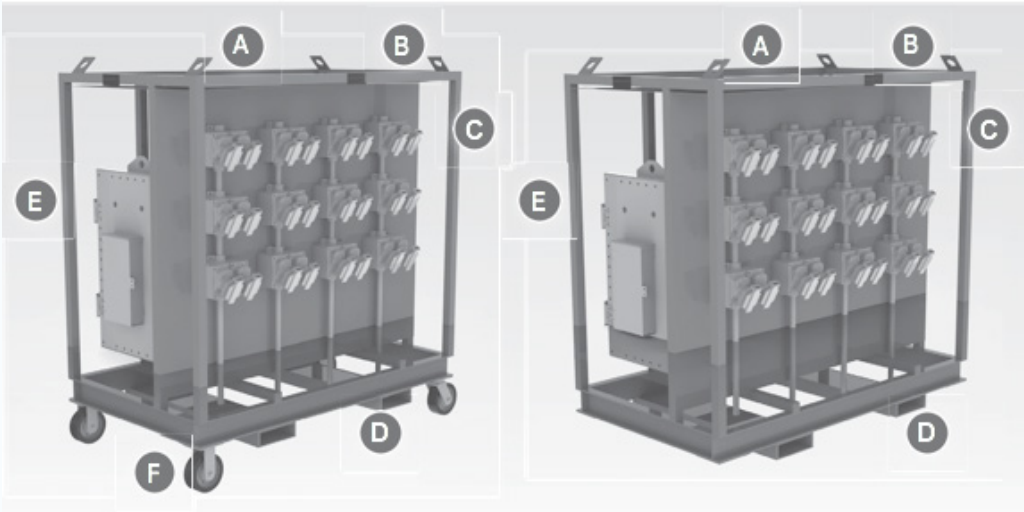

Design Features

- A** Removable Roof
- B** Lifting Eyes
- C** Durable & Robust Carbon Steel Frame
- D** Forklift Confinement Tubes
- E** Enclosed Design Protects Components
- F** Caster, Pneumatic, Semi-Pneumatic, or Solid Rubber Wheel Options

Specifications:

Hazardous			Industrial Non-Hazardous		
Specifications			Specifications		
Primary Voltage: 240 – 600V	Max Secondary Current: 225A		Primary Voltage: 240 – 600V	Max Secondary Current: 225A	
Max Primary Current: 100A	Max Secondary Current w/ Main: 100A		Max Primary Current: 00A	Max Secondary Current w/ Main: 225A	
Max Secondary Voltage: 480V			Max Secondary Voltage: 480V		
Compatible Components			Compatible Components		
Receptacles	Transformers	Panelboards	Receptacles	Transformers	Panelboards
CPS	30 kVA	EPLBN 24 circuit	CPS AR	25 kVA	18 circuit
ENR	45KVA	EXDBN 24 circuit	ENR WSQC	30 kVA	30 circuit
CES			CES WLRS	37.5 kVA	42 Circuit
FSQC		Disconnects	FSQC WLRD	45 kVA	
CESD		EIB		50 kVA	Disconnects
				75 kVA	30A, 60A, 100A, 200A

Cart/Skid Sizes:

Non-Hazardous			HAZARDOUS Non-Hazardous		
Cart / Skid 1	Cart / Skid 2	Cart / Skid 3	Cart / Skid 4	Cart / Skid 5	Cart / Skid 6
Width: 30"	Width: 42"	Width: 40"	Width: 33"	Width: 42"	Width: 62"
Length: 40"	Length: 46"	Length: 62"	Length: 62"	Length: 62"	Length: 62"
Height: 58"	Height: 58"	Height: 58"	Height: 58"	Height: 58"	Height: 58"